



DS80C390 Dual CAN High-Speed Microprocessor

www.dalsemi.com

FEATURES

- 80C52 compatible
 - 8051 instruction-set compatible
 - Five 8-bit I/O ports
 - Three 16-bit timer/counters
 - 256 bytes scratchpad RAM
- High-Speed Architecture
 - 4 clocks/machine cycle (8051=12)
 - Runs DC to 40 MHz clock rates
 - Frequency multiplier reduces EMI
 - Single-cycle instruction in 100 ns
 - 16/32-bit math coprocessor
- 4 kB internal SRAM usable as program/data/stack memory
- Enhanced memory architecture
 - Addresses up to 4 MB external
 - Defaults to true 8051 memory compatibility
 - User-enabled 22-bit program/data counter
 - 16-Bit/22-bit paged/22-bit contiguous modes
 - User-selectable multiplexed / non-multiplexed memory interface
 - Optional 10 bit stack pointer
- Two full-function CAN 2.0B controllers
 - 15 message centers per controller
 - Standard 11-bit or extended 29-bit identification modes
 - Supports DeviceNet, SDS, and higher layer CAN protocols
 - Disables transmitter during autobaud
 - SIESTA low power mode
- Two full-duplex hardware serial ports
- Programmable IRDA clock
- High integration controller includes
 - Power-fail reset
 - Early-warning power-fail interrupt
 - Programmable watchdog timer
 - Oscillator-fail detection
- 16 total interrupt sources with 6 external
- Available in 64-pin QFP, 68-pin PLCC

PIN ASSIGNMENT

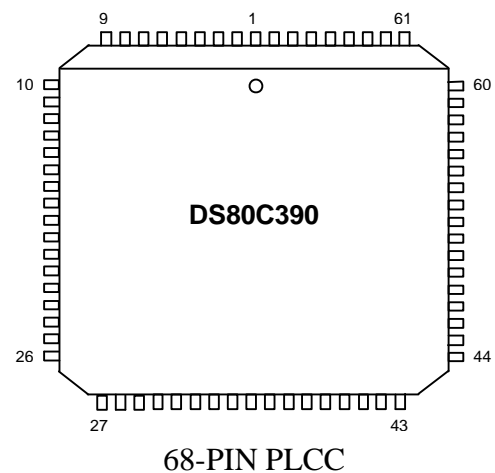
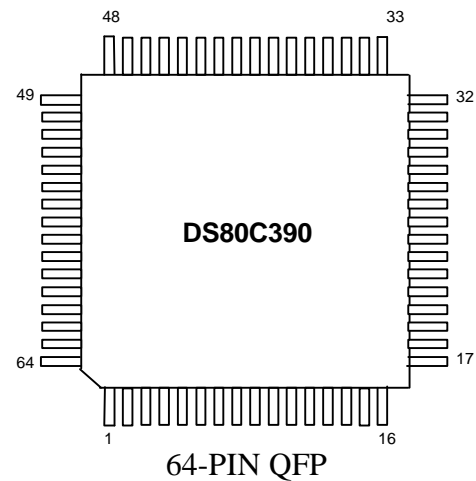

DESCRIPTION

The DS80C390 is a fast 8051-compatible microprocessor. The redesigned processor core executes 8051 instructions up to 3 times faster than the original for the same crystal speed. The DS80C390 supports a maximum crystal speed of 40 MHz, resulting in apparent execution speeds of 100 MHz (approximately 2.5X). An optional internal frequency multiplier allows the microprocessor to operate at full speed with a reduced crystal frequency, reducing EMI. A hardware math accelerator further increases the speed of 32 and 16 bit multiply and divide operations, as well as high-speed shift, normalization and accumulate functions.

The DS80C390 features two full-function Controller Area Network (CAN) 2.0B controllers. Status and control registers are distributed between SFRs and 512 bytes of internal MOVX memory for maximum flexibility. In addition to standard 11-bit or 29-extended message identifiers, the device supports two separate 8-bit media masks and media arbitration fields to support the use of higher-level CAN protocols such as DeviceNet and SDS.

All of the standard 8051 resources such as three timer/counters, serial port, and five 8-bit I/O ports are included in the DS80C390. In addition it includes a second hardware serial port, seven additional interrupts, programmable watchdog timer, brown-out monitor, power-fail reset, and a programmable output clock that supports an IRDA interface. The device provides dual data pointers with increment/decrement features to speed block data memory moves. It also can adjust the speed of MOVX data memory access from two to twelve machine cycles for flexibility in addressing external memory and peripherals.

The device incorporates a 4kB SRAM, which can be configured as various combinations of MOVX memory, program memory, and optional stack memory. A 22-bit program counter supports access to a maximum of 4 MB of external program memory and 4 MB of external data memory. A 10-bit stack pointer addresses up to 1kB of MOVX memory for increased code efficiency.

A new Power Management Mode (PMM) is useful for portable or power-conscious applications. This feature allows software to switch from the standard machine cycle rate of 4 clocks per cycle to 1024 clocks per cycle. For example, at 12 MHz standard operation has a machine cycle rate of 3 MHz. In Power Management Mode at the same external clock speed, software can select 11.7 kHz machine cycle rate. There is a corresponding reduction in power consumption when the processor runs slower.

The EMI reduction feature allows software to select a reduced electromagnetic interference (EMI) mode by disabling the ALE signal when it is unneeded. The device also incorporates active current control on the address and data buses, reducing EMI by minimizing transients when interfacing to external circuitry.

ORDERING INFORMATION

Part Number	Package	Max. Clock Speed	Temperature Range
DS80C390-QCR	68-pin PLCC	40 MHz	0°C to +70°C
DS80C390-FCR	64-pin PQFP	40 MHz	0°C to +70°C
DS80C390-QNR	68-pin PLCC	40 MHz	-40°C to +85°C
DS80C390-FNR	64-pin PQFP	40 MHz	-40°C to +85°C

PIN DESCRIPTION Table 1

PQFP	PLCC	SIGNAL NAME	DESCRIPTION
8, 22, 40, 56	17, 32, 51, 68	V _{CC}	+5V
9, 25, 41, 57	1, 18, 35, 52	GND	Digital Circuit Ground
46	57	ALE	Address Latch Enable - Output. When the $\overline{\text{MUX}}$ pin is low, this pin outputs a clock to latch the external address LSB from the multiplexed address/data bus on Port 0. This signal is commonly connected to the latch enable of an external transparent latch. ALE has a pulse width of 1.5 XTAL1 cycles and a period of four XTAL1 cycles. When the $\overline{\text{MUX}}$ pin is high, the pin will toggle continuously if the ALEOFF bit is cleared. ALE is forced high when the device is in a Reset condition or if the ALEOFF bit is set while the $\overline{\text{MUX}}$ pin is high.
45	56	$\overline{\text{PSEN}}$	Program Store Enable - Output. This signal is the chip enable for external ROM memory. $\overline{\text{PSEN}}$ provides an active low pulse and is driven high when external ROM is not being accessed.
47	58	$\overline{\text{EA}}$	External Access Enable - Input. This pin must be tied to GND for proper operation.
26	36	$\overline{\text{MUX}}$	Multiplex/Demultiplex Select - Input. This pin selects if the address/data bus operates in multiplexed ($\overline{\text{MUX}}=0$) or demultiplexed ($\overline{\text{MUX}}=1$) mode.
2	11	RST	Reset - Input. The RST input pin contains a Schmitt voltage input to recognize external active high Reset inputs. The pin also employs an internal pulldown resistor to allow for a combination of wired OR external Reset sources. An RC circuit is not required for power-up, as the device provides this function internally.
3	12	$\overline{\text{RSTOL}}$	Reset Output Low - Output. This active low signal will be asserted: When the processor has entered reset via the RST pin, During the crystal warm-up period following power-on or Stop mode, During a watchdog timer reset (2 cycles duration), During an oscillator failure (if OFDE=1), Whenever $V_{CC} \leq V_{RST}$
23, 24	33, 34	XTAL2, XTAL1	XTAL1, XTAL2 - Crystal oscillator pins support fundamental mode, parallel resonant, AT cut crystals. XTAL1 is the input if an external clock source is used in place of a crystal. XTAL2 is the output of the crystal amplifier.
55 54 53 52 51 50 49 48	67 66 65 64 63 62 61 59	AD0 / D0 AD1 / D1 AD2 / D2 AD3 / D3 AD4 / D4 AD5 / D5 AD6 / D6 AD7 / D7	AD0-7 (Port 0) - I/O. When the $\overline{\text{MUX}}$ pin is tied low, Port 0 is the multiplexed address/data bus. While ALE is high, the LSB of a memory address is presented. While ALE falls, the port transitions to a bi-directional data bus. When the $\overline{\text{MUX}}$ pin is tied high, Port 0 functions as the bi-directional data bus. Port 0 cannot be modified by software. The reset condition of Port 0 pins is high. No pullup resistors are needed.
58-64, 1	2-8, 10	P1.0-P1.7	Port 1 - I/O. Port 1 can function as an 8-bit bi-directional I/O port,

			<p>the non-multiplexed A0 - A7 signals (when the $\overline{\text{MUX}}$ pin is tied high), and as an alternate functional interface for several internal resources. Setting the SP1EC bit will relocate the RXD1 and TXD1 functions to Port 5. The reset condition of Port 1 is all bits at logic 1 via a weak pullup. The logic 1 state also serves as an input mode, since external circuits writing to the port can overdrive the weak pullup. When software clears any port pin to 0, a strong pulldown is activated that remains on until either a 1 is written to the port pin or a reset occurs. Writing a 1 after the port has been at 0 will activate a strong transition driver, followed by a weaker sustaining pullup. Once the momentary strong driver turns off, the port once again becomes the output (and input) high state.</p> <p>Port Alternate Function</p>
58	2	A0	P1.0 T2 External I/O for Timer/Counter 2
59	3	A1	P1.1 T2EX Timer/Counter 2 Capture/Reload Trigger
60	4	A2	P1.2 RXD1 Serial Port 1 Input
61	5	A3	P1.3 TXD1 Serial Port 1 Output
62	6	A4	P1.4 $\overline{\text{INT2}}$ External Interrupt 2 (Pos. Edge Detect)
63	7	A5	P1.5 $\overline{\text{INT3}}$ External Interrupt 3 (Neg. Edge Detect)
64	8	A6	P1.6 $\overline{\text{INT4}}$ External Interrupt 4 (Pos. Edge Detect)
1	10	A7	P1.7 $\overline{\text{INT5}}$ External Interrupt 5 (Neg. Edge Detect)
35	46	A8 (P2.0)	A15-A8 (Port 2) - Output. Port 2 serves as the MSB for external addressing. The port automatically asserts the address MSB during external ROM and RAM access. Although the Port 2 SFR exists, the SFR value will never appear on the pins (due to memory access). Therefore accessing the Port 2 SFR is only useful for MOVX A, @Ri or MOVX @Ri, A instructions, which use the Port 2 SFR as the external address MSB.
36	47	A9 (P2.1)	
37	48	A10 (P2.2)	
38	49	A11 (P2.3)	
39	50	A12 (P2.4)	
42	53	A13 (P2.5)	
43	54	A14 (P2.6)	
44	55	A15 (P2.7)	
4-7, 10-13	13-16, 19-22	P3.0-P3.7	<p>Port 3 - I/O. Port 3 can function as an 8-bit bi-directional I/O port, and as an alternate functional interface for several internal resources similar to the traditional 8051. The reset condition of Port 1 is all bits at logic 1 via a weak pullup. The logic 1 state also serves as an input mode, since external circuits writing to the port can overdrive the weak pullup. When software clears any port pin to 0, the device activates a strong pulldown that remains on until either a 1 is written to the port pin or a reset occurs. Writing a 1 after the port has been at 0 will activate a strong transition driver, followed by a weaker sustaining pullup. Once the momentary strong driver turns off, the port once again becomes the output (and input) high state.</p> <p>Port Alternate Function</p>
4	13		P3.0 RXD0 Serial Port 0 Input
5	14		P3.1 TXD0 Serial Port 0 Output
6	15		P3.2 $\overline{\text{INT0}}$ External Interrupt 0
7	16		P3.3 $\overline{\text{INT1}}$ External Interrupt 1
10	19		P3.4 T0 Timer 0 External Input

11	20		P3.5 T1/XCLK Timer 1 External Input/External Clock Output
12	21		P3.6 \overline{WR} External Data Memory Write Strobe
13	22		P3.7 \overline{RD} External Data Memory Read Strobe
34-27	45, 44, 42-37	P4.0-P4.7	Port 4 - I/O. Port 4 can function as an 8-bit bi-directional I/O port, and as the source for external address and chip enable signals for program and data memory. Port pins are configured as I/O or memory signals via the P4CNT register. The reset condition of Port 1 is all bits at logic 1 via a weak pullup. The logic 1 state also serves as an input mode, since external circuits writing to the port can overdrive the weak pullup. When software clears any port pin to 0, the device activates a strong pulldown that remains on until either a 1 is written to the port pin or a reset occurs. Writing a 1 after the port has been at 0 will activate a strong transition driver, followed by a weaker sustaining pullup. Once the momentary strong driver turns off, the port once again becomes the output (and input) high state. Port Alternate Function
34	45		P4.0 $\overline{CE0}$ Program Memory Chip Enable 0
33	44		P4.1 $\overline{CE1}$ Program Memory Chip Enable 1
32	42		P4.2 $\overline{CE2}$ Program Memory Chip Enable 2
31	41		P4.3 $\overline{CE3}$ Program Memory Chip Enable 3
30	40		P4.4 A16 Program/Data Memory Address 16
29	39		P4.5 A17 Program/Data Memory Address 17
28	38		P4.6 A18 Program/Data Memory Address 18
27	37		P4.7 A19 Program/Data Memory Address 19
21-14	31-27, 25-23	P5.0-P5.7	Port 5 - I/O. Port 5 can function as an 8-bit bi-directional I/O port, the CAN interface, or as the source for peripheral enable signals for data memory. Setting the SP1EC bit will relocate the RXD1 and TXD1 functions from P1.3-P1.2 to P5.3-P5.2 as described in the User's Guide. The reset condition of Port 1 is all bits at logic 1 via a weak pullup. The logic 1 state also serves as an input mode, since external circuits writing to the port can overdrive the weak pullup. When software clears any port pin to 0, the device activates a strong pulldown that remains on until either a 1 is written to the port pin or a reset occurs. Writing a 1 after the port has been at 0 will activate a strong transition driver, followed by a weaker sustaining pullup. Once the momentary strong driver turns off, the port once again becomes the output (and input) high state. Port Alternate Function
21	31		P5.0 C0TX CAN0 Transmit Output
20	30		P5.1 C0RX CAN0 Receive Input
19	29		P5.2 C1TX CAN1 Transmit Output (optional TXD1)
18	28		P5.3 C1RX CAN1 Receive Input (optional RXD1)
17	27		P5.4 $\overline{PCE0}$ Peripheral Chip Enable 0

16	25		P5.5 <u>PCE1</u> Peripheral Chip Enable 1
15	24		P5.6 <u>PCE2</u> Peripheral Chip Enable 2
14	23		P5.7 <u>PCE3</u> Peripheral Chip Enable 3
	9, 26, 43, 60		NC - Reserved. These pins are reserved for use with future devices in this family and should not be connected.

80C32 COMPATIBILITY

The DS80C390 is a CMOS 80C32-compatible microcontroller designed for high performance. Every effort has been made to keep the core device familiar to 80C32 users while adding many new features. Because the device runs the standard 8051 instruction set, in general software written for existing 80C32-based systems will work on the DS80C390. The primary exceptions are related to timing-critical issues, since the high-performance core of the microcontroller executes instructions much faster than the original. Memory interfacing is performed identically to the standard 80C32. The high-speed nature of the DS80C390 core will slightly change the interface timing, and designers are advised to consult the timing diagrams in this data sheet for more information.

The DS80C390 provides the same timer/counter resources, full duplex serial port, 256 bytes of scratchpad RAM and I/O ports as the standard 80C32. Timers will default to a 12 clocks per machine cycle operation to keep timing compatible with original 8051 systems, but can be programmed to run at the faster 4 clocks per machine cycle if desired. New hardware functions are accessed using Special Function Registers that do not overlap with standard 80C32 locations.

This data sheet provides only a summary and overview of the DS80C390. Detailed descriptions are available in the corresponding user's guide. This data sheet assumes a familiarity with the architecture of the standard 80C32. In addition to the basic features of that device, the DS80C390 incorporates many new features.

PERFORMANCE OVERVIEW

The DS80C390's higher performance comes not just from increasing the clock frequency, but from a more efficient design. This updated core removes the dummy memory cycles that are present in a standard, 12 clocks per machine cycle 8051. In the DS80C390, the same machine cycle takes 4 clocks. Thus the fastest instruction, 1 machine cycle, executes 3 times faster for the same crystal frequency. The majority of instructions on the DS80C390 will see the full 3 to 1 speed improvement, while a few will execute between 1.5 and 2.4 times faster. Regardless of specific performance improvements, all instructions are faster than the original 8051.

Improvement of individual programs will depend on the actual mix of instructions used. Speed sensitive applications should make the most use of instructions that are 3 times faster. However, the large number of 3 to 1 improved opcodes makes dramatic speed improvements likely for any arbitrary combination of instructions. These architecture improvements and the sub-micron CMOS design produce a peak instruction cycle in 100 ns (10 MIPs). The Dual Data Pointer feature also allows the user to eliminate wasted instructions when moving blocks of memory.

INSTRUCTION SET SUMMARY

All instructions perform exactly the same functions as their 8051 counterparts. Their effect on bits, flags, and other status functions is identical. However, the timing of instructions is different, both in absolute and relative number of clocks. The absolute timing of software loops can be calculated using a table in the user's guide. However, counter/timers default to run at the traditional 12 clocks per increment. In this way, timer-based events occur at the standard intervals with software executing at higher speed.

Timers optionally can run at the faster 4 clocks per increment to take advantage of faster processor operation.

The relative time of two DS80C390 instructions might differ from the traditional 8051. For example, in the original architecture the “MOVX A, @DPTR” instruction and the “MOV direct, direct” instruction required the same amount of time: two machine cycles or 24 oscillator cycles. In the DS80C390, the MOVX instruction takes as little as two machine cycles or 8 oscillator cycles but the “MOV direct, direct” uses three machine cycles or 12 oscillator cycles. While both are faster than their original counterparts, they now have different execution times. This is because the device usually uses one instruction cycle for each instruction byte. Examine the timing of each instruction for familiarity with the changes. Note that a machine cycle now requires just 4 clocks, and provides one ALE pulse per cycle. Many instructions require only one cycle, but some require five. Refer to the user’s guide for details and individual instruction timing.

SPECIAL FUNCTION REGISTERS

Special Function Registers (SFRs) control most special features of the microcontroller. This allows the device to have many new features but use the same instruction set as the 8051. When writing software to use a new feature, an equate statement defines the SFR to an assembler or compiler. This is the only change needed to access the new function. The DS80C390 duplicates the SFRs contained in the standard 80C52. Table 2 shows the register addresses and bit locations. Many are standard 80C52 registers. The user’s guide contains a full description of all SFRs.

SPECIAL FUNCTION REGISTER LOCATION Table 2

Register	Bit7	Bit6	Bit5	Bit4	Bit3	Bit2	Bit1	Bit0	ADDRESS
P4	P4.7	P4.6	P4.5	P4.4	P4.3	P4.2	P4.1	P4.0	80h
SP									81h
DPL									82h
DPH									83h
DPL1									84h
DPH1									85h
DPS	ID1	ID0	TSL	-	-	-	-	SEL	86h
PCON	SMOD_0	SMOD0	OFDF	OFDE	GF1	GF0	STOP	IDLE	87h
TCON	TF1	TR1	TF0	TR0	IE1	IT1	IE0	IT0	88h
TMOD	GATE	C/T	M1	M0	GATE	C/T	M1	M0	89h
TL0									8Ah
TL1									8Bh
TH0									8Ch
TH1									8Dh
CKCON	WD1	WD0	T2M	T1M	T0M	MD2	MD1	MD0	8Eh
P1	INT5/P1.7	INT4/P1.6	INT3/P1.5	INT2/P1.4	TXD1/P1.3	RXD1/P1.2	T2EX/P1.1	T2/P1.0	90h
EXIF	IE5	IE4	IE3	IE2	CKRY	RGMD	RGSL	BGS	91h
P4CNT	-	SBCAN	P4CNT.5	P4CNT.4	P4CNT.3	P4CNT.2	P4CNT.1	P4CNT.0	92h
DPX									93h
DPX1									95h
C0RMS0									96h
C0RMS1									97h
SCON0	SM0/FE_0	SM1_0	SM2_0	REN_0	TB8_0	RB8_0	TI_0	RI_0	98h
SBUF0									99h
ESP	-	-	-	-	-	-	ESP.1	ESP.0	9Bh
AP									9Ch
ACON	-	-	-	-	-	SA	AM1	AM0	9Dh
C0TMA0									9Eh
C0TMA1									9Fh

P2	P2.7	P2.6	P2.5	P2.4	P2.3	P2.2	P2.1	P2.0	A0h
P5	P5.7	P5.6	P5.5	P5.4	P5.3	P5.2	P5.1	P5.0	A1h
P5CNT	CAN1BA	CAN0BA	SP1EC	C1_I/O	C0_I/O	P5CNT.2	P5CNT.1	P5CNT.0	A2h
C0C	ERIE	STIE	PDE	SIESTA	CRST	AUTOB	ERCS	SWINT	A3h
C0S	BSS	EC96/128	WKS	RXS	TXS	ER2	ER1	ER0	A4h
C0IR	INTIN7	INTIN6	INTIN5	INTIN4	INTIN3	INTIN2	INTIN1	INTIN0	A5h
C0TE									A6h
C0RE									A7h
IE	EA	ES1	ET2	ES0	ET1	EX1	ET0	EX0	A8h
SADDR0									A9h
SADDR1									AAh
C0M1C	MSRDY	ETI	ERI	INTRQ	EXTRQ	MTRQ	ROW/TIH	DTUP	ABh
C0M2C	MSRDY	ETI	ERI	INTRQ	EXTRQ	MTRQ	ROW/TIH	DTUP	ACh
C0M3C	MSRDY	ETI	ERI	INTRQ	EXTRQ	MTRQ	ROW/TIH	DTUP	ADh
C0M4C	MSRDY	ETI	ERI	INTRQ	EXTRQ	MTRQ	ROW/TIH	DTUP	AEnh
C0M5C	MSRDY	ETI	ERI	INTRQ	EXTRQ	MTRQ	ROW/TIH	DTUP	AFh
P3	P3.7	P3.6	T1	T0	INT1	INT0	TXD0	RXD0	B0h
C0M6C	MSRDY	ETI	ERI	INTRQ	EXTRQ	MTRQ	ROW/TIH	DTUP	B3h
C0M7C	MSRDY	ETI	ERI	INTRQ	EXTRQ	MTRQ	ROW/TIH	DTUP	B4h
C0M8C	MSRDY	ETI	ERI	INTRQ	EXTRQ	MTRQ	ROW/TIH	DTUP	B5h
C0M9C	MSRDY	ETI	ERI	INTRQ	EXTRQ	MTRQ	ROW/TIH	DTUP	B6h
C0M10C	MSRDY	ETI	ERI	INTRQ	EXTRQ	MTRQ	ROW/TIH	DTUP	B7h
IP	-	PS1	PT2	PS0	PT1	PX1	PT0	PX0	B8h
SADEN0									B9h
SADEN1									BAh
C0M11C	MSRDY	ETI	ERI	INTRQ	EXTRQ	MTRQ	ROW/TIH	DTUP	BBh
C0M12C	MSRDY	ETI	ERI	INTRQ	EXTRQ	MTRQ	ROW/TIH	DTUP	BCh
C0M13C	MSRDY	ETI	ERI	INTRQ	EXTRQ	MTRQ	ROW/TIH	DTUP	BDh
C0M14C	MSRDY	ETI	ERI	INTRQ	EXTRQ	MTRQ	ROW/TIH	DTUP	BEh
C0M15C	MSRDY	ETI	ERI	INTRQ	EXTRQ	MTRQ	ROW/TIH	DTUP	BFh
SCON1	SM0/FE_1	SM1_1	SM2_1	REN_1	TB8_1	RB8_1	TI_1	RI_1	C0h
SBUF1									C1h
PMR	CD1	CD0	SWB	CTM	4X/2X	ALEOFF	-	-	C4h
STATUS	PIP	HIP	LIP	-	SPTA1	SPRA1	SPTA0	SPRA0	C5h
MCON	IDM1	IDM0	CMA	-	PDCE3	PDCE2	PDCE1	PDCE0	C6h
TA									C7h
T2CON	TF2	EXF2	RCLK	TCLK	EXEN2	TR2	C/T2	CP/RL2	C8h
T2MOD	-	-	-	D13T1	D13T2	-	T2OE	DCEN	C9h
RCAP2L									CAh
RCAP2H									CBh
TL2									CCh
TH2									CDh
COR	IRDACK	C1BPR7	C1BPR6	C0BPR7	C0BPR6	COD1	COD0	CLKOE	CEh
PSW	CY	AC	F0	RS1	RS0	OV	F1	P	D0h
MCNT0	LSHIFT	CSE	SCB	MAS4	MAS3	MAS2	MAS1	MAS0	D1h
MCNT1	MST	MOF	-	CLM	-	-	-	-	D2h
MA									D3h
MB									D4h
MC									D5h
C1RMS0									D6h
C1RMS1									D7h
WDCON	SMOD_1	POR	EPFI	PFI	WDIF	WTRF	EWT	RWT	D8h
C1TMA0									DEh
C1TMA1									DFh
ACC									E0h
C1C	ERIE	STIE	PDE	SIESTA	CRST	AUTOB	ERCS	SWINT	E3h

C1S	BSS	CECE	WKS	RXS	TXS	ER2	ER1	ER0	E4h
C1IR	INTIN7	INTIN6	INTIN5	INTIN4	INTIN3	INTIN2	INTIN1	INTIN0	E5h
C1TE									E6h
C1RE									E7h
EIE	CANBIE	COIE	C1IE	EWDI	EX5	EX4	EX3	EX2	E8h
MXAX									EAh
C1M1C	MSRDY	ETI	ERI	INTRQ	EXTRQ	MTRQ	ROW/TIH	DTUP	EBh
C1M2C	MSRDY	ETI	ERI	INTRQ	EXTRQ	MTRQ	ROW/TIH	DTUP	ECh
C1M3C	MSRDY	ETI	ERI	INTRQ	EXTRQ	MTRQ	ROW/TIH	DTUP	EDh
C1M4C	MSRDY	ETI	ERI	INTRQ	EXTRQ	MTRQ	ROW/TIH	DTUP	EEh
C1M5C	MSRDY	ETI	ERI	INTRQ	EXTRQ	MTRQ	ROW/TIH	DTUP	EFh
B									F0h
C1M6C	MSRDY	ETI	ERI	INTRQ	EXTRQ	MTRQ	ROW/TIH	DTUP	F3h
C1M7C	MSRDY	ETI	ERI	INTRQ	EXTRQ	MTRQ	ROW/TIH	DTUP	F4h
C1M8C	MSRDY	ETI	ERI	INTRQ	EXTRQ	MTRQ	ROW/TIH	DTUP	F5h
C1M9C	MSRDY	ETI	ERI	INTRQ	EXTRQ	MTRQ	ROW/TIH	DTUP	F6h
C1M10C	MSRDY	ETI	ERI	INTRQ	EXTRQ	MTRQ	ROW/TIH	DTUP	F7h
EIP	CANBIP	COIP	C1IP	PWDI	PX5	PX4	PX3	PX2	F8h
C1M11C	MSRDY	ETI	ERI	INTRQ	EXTRQ	MTRQ	ROW/TIH	DTUP	FBh
C1M12C	MSRDY	ETI	ERI	INTRQ	EXTRQ	MTRQ	ROW/TIH	DTUP	FCh
C1M13C	MSRDY	ETI	ERI	INTRQ	EXTRQ	MTRQ	ROW/TIH	DTUP	FDh
C1M14C	MSRDY	ETI	ERI	INTRQ	EXTRQ	MTRQ	ROW/TIH	DTUP	FEh
C1M15C	MSRDY	ETI	ERI	INTRQ	EXTRQ	MTRQ	ROW/TIH	DTUP	FFh

*Shaded bits are Timed Access protected.

ON-CHIP ARITHMETIC ACCELERATOR

An on-chip math accelerator allows the microcontroller to perform 32- and 16-bit multiplication, division, shifting, and normalization using dedicated hardware. Math operations are performed by sequentially loading three special registers. The mathematical operation is determined by the sequence in which three dedicated SFRs (MA, MB and MC) are accessed, eliminating the need for a special step to choose the operation. The normalize function facilitates the conversion of 4-byte unsigned binary integers into floating point format. The following table shows the operations supported by the math accelerator and their time of execution.

ARITHMETIC ACCELERATOR EXECUTION TIMES Table 3

Operation	Result	Execution Time
32-bit/16-bit divide	32-bit quotient, 16-bit remainder	36 t_{CLCL}
16-bit/16-bit divide	16-bit quotient, 16-bit remainder	24 t_{CLCL}
16-bit/16-bit multiply	32-bit product	24 t_{CLCL}
32-bit shift left/right	32-bit result	36 t_{CLCL}
32-bit normalize	32-bit mantissa, 5 bit exponent	36 t_{CLCL}

The following table demonstrates the procedure to perform mathematical operations using the hardware math accelerator. The MA and MB registers must be loaded and read in the order shown for proper operation, although accesses to any other registers can be performed between access to the MA or MB registers. An access to the MA, MB, or MC registers out of sequence will corrupt the operation, requiring the software to clear the MST bit to restart the math accelerator state machine. Consult the description of the MCNT0 SFR for details of how the shift and normalize functions operate.

ARITHMETIC ACCELERATOR SEQUENCING

Divide (32/16 or 16/16)	Multiply (16x16)
Load MA with divisor LSB. <i>Load MA with divisor LSB+1*</i> <i>Load MA with divisor LSB+2*</i> Load MA with divisor MSB. Load MB with dividend LSB. Load MB with dividend MSB. Poll the MST bit until cleared (9 machine cycles). Read MA to retrieve the quotient MSB. Read MA to retrieve the quotient LSB+2. Read MA to retrieve the quotient LSB+1. Read MA to retrieve the quotient LSB. Read MB to retrieve the remainder MSB. Read MB to retrieve the remainder LSB. *Not performed for 16 bit numerator.	Load MB with multiplier LSB. Load MB with multiplier MSB. Load MA with multiplicand LSB. Load MA with multiplicand MSB. Poll the MST bit until cleared (6 machine cycles). Read MA for product MSB. Read MA for product LSB+2. Read MA for product LSB+1. Read MA for product LSB.
Shift Right/Left	Normalize
Load MA with data LSB. Load MA with data LSB+1. Load MA with data LSB+2. Load MA with data MSB. Configure MCNT0 register as required Poll the MST bit until cleared. (9 machine cycles) Read MA for result MSB. Read MA for result LSB+2. Read MA for result LSB+1. Read MA for result LSB.	Load MA with data LSB. Load MA with data LSB+1. Load MA with data LSB+2. Load MA with data MSB. Configure MCNT0 register as required. Poll the MST bit until cleared (9 machine cycles). Read MA for mantissa MSB. Read MA for mantissa LSB+2. Read MA for mantissa LSB+1. Read MA for mantissa LSB. Read MCNT0.4-MCNT0.0 for exponent.

40-BIT ACCUMULATOR

The accelerator also incorporates an automatic accumulator function, permitting the implementation of multiply-and-accumulate and divide-and-accumulate functions without any additional delay. Each time the accelerator is used for a multiply or divide operation, the result is transparently added to a 40-bit accumulator. This can greatly increase speed of DSP and other high-level math operations.

The accumulator can be accessed any time the Multiply/Accumulate Status Flag (MCNT1;D2h) is cleared. The accumulator is initialized by performing five writes to the Multiplier C Register (MC;D5h), LSB first. The 40-bit accumulator can be read by performing five reads of the Multiplier C Register, MSB first.

MEMORY ADDRESSING

The DS80C390 incorporates three internal memory areas:

- 256 bytes of scratchpad (or direct) RAM
- 4 KB of SRAM configurable as various combinations of MOVX data memory, stack memory, and MOVC program memory
- 512 bytes of RAM reserved for the CAN message centers.

Up to 4 MB of external memory is addressed via a multiplexed or demultiplexed 20-bit address bus/8-bit data bus and four chip enable (active during program memory access) or four peripheral enable (active during data memory access) signals.

Three different addressing modes are supported, as selected by the AM1, AM0 bits in the ACON SFR.

16-bit address mode

16-bit address mode accesses memory similarly to the traditional 8051. It is opcode compatible with the 8051 microprocessor and identical to the byte and cycle count of the Dallas Semiconductor High-Speed Microcontroller family. A device operating in this mode can access up to 64 KB of program and data memory. The device defaults to this mode following any reset.

22-bit paged address mode

The 22-bit paged address mode retains binary code compatibility with the 8051 instruction set, but adds one machine cycle to the ACALL, LCALL, RET and RETI instructions with respect to the Dallas Semiconductor High-Speed Microcontroller family timing. This is transparent to standard 8051 compilers. Interrupt latency is also increased by one machine cycle.

22-bit contiguous address mode

The 22-bit contiguous addressing mode uses a full 22-bit program counter, and all modified branching instructions automatically save and restore the entire program counter. The 22-bit branching instructions such as ACALL, AJMP, LCALL, LJMP, MOV DPTR, RET and RETI instructions require an assembler, compiler and linker that specifically supports these features. The INC DPTR is lengthened by one cycle but remains byte count compatible with the standard 8051 instruction set.

Internally, the device uses a 22-bit program counter. The lowest order 22 bits are used for memory addressing, with a special 23rd bit used to map the 4KB SRAM above the 4 MB memory space in bootstrap loader applications. Address bits 16-23 for the 22-bit addressing modes are generated via additional SFRs dependent on the type of instruction as shown below.

EXTENDED ADDRESS GENERATION: Table 2

	Address bits 23-16	Address bits 15-8	Address bits 7-0
MOVX instructions using DPTR	DPX;93h	DPH;83h	DPL;82h
MOVX instructions using DPTR1	DPX1;95h	DPH1;85h	DPL1;84h
MOVX instructions using @Ri	MXAX;EAh	P2;A0h	Ri
Addressing program memory in 22-bit paged mode	AP;9Ch	--	--
10-bit stack pointer mode	--	ESP;9Bh	SP;81h

INTERNAL MOVX SRAM

The DS80C390 contains 4kB of SRAM that can be configured as CAN message centers, user accessible MOVX memory, program memory, or optional stack memory. The specific configuration and locations

are governed by the Internal Data Memory Configuration bits (IDM1 and IDM0) in the Memory Control Register (MCON:C6h). Note that when the SA bit (ACON.2) is set, the first 1kB of the MOVX data memory is reserved for use by the 10-bit expanded stack. Accesses to internal memory locations will not generate WR , RD , or PSEN strobes.

The DS80C390 has the ability to configure its 4kB of internal SRAM as combined program and data memory. This allows the application software to execute self-modifiable code. The technique loads the 4kB SRAM with bootstrap loader software, and then modifies the IDM1 and IDM0 bits to map the 4kB starting at memory location 40000h. This allows the system to run the bootstrap loader without disturbing the 4 MB external memory bus, making the device in-system reprogrammable for Flash or NV RAM.

INTERNAL MOVX SRAM CONFIGURATION Table 4

IDM1	IDM0	CMA	MOVX Data Memory	CAN Message Memory	Shared Program /Data Memory
0	0	0	00F000h-00FFFFh	00EE00h-00EFFFh	--
0	0	1	00F000h-00FFFFh	401000h-4011FFh	--
0	1	0	000000h-000FFFh	00EE00h-00EFFFh	--
0	1	1	000000h-000FFFh	401000h-4011FFh	--
1	0	0	400000h-400FFFh	00EE00h-00EFFFh	--
1	0	1	400000h-400FFFh	401000h-4011FFh	--
1	1	0	--	00EE00h-00EFFFh	400000h-400FFFh*
1	1	1	--	401000h-4011FFh	400000h-400FFFh*

*10-bit expanded stack not available in Shared Program /Data Memory mode.

EXTERNAL MEMORY ADDRESSING

The enabling and mapping of the chip enable signals is done via the Port 4 Control Register (P4CNT;92h) and Memory Control Register (MCON;96h); The Extended Address and Chip Enable Generation Table shows which chip enable and address line signals are active on Port 4. Following reset, the device will be configured with P4.7-P4.4 as address lines and P4.3-P4.0 configured as $\overline{CE3-0}$, with the first program fetch being performed from 00000h with $\overline{CE0}$ active. The following tables illustrate which memory ranges are controlled by each chip enable as a function of which address lines are enabled.

EXTERNAL MEMORY ADDRESSING PIN ASSIGNMENTS Table 5

Address/Data Bus	$\overline{CE3-CE0}$	$\overline{PCE3-PCE0}$	Addr 19-16	Addr 15-8	Addr 7-0	Data Bus
Multiplexed	P4.3-P4.0	P5.7-P5.4	P4.7-P4.4	P2	P0	P0
Demultiplexed	P4.3-P4.0	P5.7-P5.4	P4.7-P4.4	P2	P1	P0

EXTENDED ADDRESS AND CHIP ENABLE GENERATION Table 6

P4CNT.5-3	Port 4 Pin Function				P4CNT.2-0	Port 4 Pin Function			
	P4.7	P4.6	P4.5	P4.4		P4.3	P4.2	P4.1	P4.0
000	I/O	I/O	I/O	I/O	000	I/O	I/O	I/O	I/O
100	I/O	I/O	I/O	A16	100	I/O	I/O	I/O	$\overline{CE0}$
101	I/O	I/O	A17	A16	101	I/O	I/O	$\overline{CE1}$	$\overline{CE0}$
110	I/O	A18	A17	A16	110	I/O	$\overline{CE2}$	$\overline{CE1}$	$\overline{CE0}$
111(default)	A19	A18	A17	A16	111(default)	$\overline{CE3}$	$\overline{CE2}$	$\overline{CE1}$	$\overline{CE0}$

PROGRAM MEMORY CHIP ENABLE BOUNDARIES Table 7

P4CNT.5-3	$\overline{CE0}$	$\overline{CE1}$	$\overline{CE2}$	$\overline{CE3}$
000	0h-7FFFh	8000h-FFFFh	10000h-17FFFh	18000h-1FFFFh
100	0h-1FFFFh	20000h-3FFFFh	40000h-5FFFFh	60000h-7FFFFh
101	0h-3FFFFh	40000h-7FFFFh	80000h-BFFFFh	C0000h-FFFFFh
110	0h-7FFFFh	80000h-FFFFFh	100000h-17FFFFh	180000h-1FFFFFh
111(default)	0-FFFFFh	100000h-1FFFFFh	200000h-2FFFFFh	300000h-3FFFFFh

The DS80C390 incorporates a feature allowing PCE and CE signals to be combined. This is useful when incorporating modifiable code memory as part of a bootstrap loader or for in-system reprogrammability.

Setting the PDCE3 : 0 (MCON.3-0) bits causes the corresponding chip enable signal to function for both MOVC and MOVX operations. Write access to combined program and data memory blocks is controlled by the \overline{WR} signal, and read access is controlled by the \overline{PSEN} signal. This feature is especially useful if the design achieves in-system reprogrammability via external Flash memory, in which a single device is accessed via both MOVC instructions (program fetch) and MOVX Write operations (updates to code memory). In this case, the internal SRAM is placed in the program/data configuration and loaded with a small bootstrap loader program stored in the external Flash memory. The device then executes the internal bootstrap loader routine to modify/update the program memory located in the external Flash memory.

STRETCH MEMORY CYCLES

The DS80C390 allows user application software to select the number of machine cycles it takes to execute a MOVX instruction, allowing access to both fast and slow off-chip data memory and/or peripherals without glue logic. High-speed systems often include memory-mapped peripherals such as LCDs or UARTs with slow access times, so it may not be necessary or desirable to access external devices at full speed. The microprocessor can perform a MOVX instruction in as little as two machine cycles or as many as twelve machine cycles. Accesses to internal MOVX SRAM always use two cycles. Note that stretch cycle settings affect external MOVX memory operations only and that there is no way to slow the accesses to program memory other than to use a slower crystal (or external clock).

External MOVX timing is governed by the selection of 0 to 7 Stretch cycles, controlled by the MD2-MD0 SFR bits in the Clock Control Register (CKCON.2-0). A Stretch of zero will result in a two-machine cycle MOVX instruction. A Stretch of seven will result in a MOVX of twelve machine cycles. Software can dynamically change the Stretch value depending on the particular memory or peripheral being accessed. The default of one Stretch cycle allows the use of commonly available SRAMs without dramatically lengthening the memory access times.

Stretch cycle settings affect external MOVX timing in three gradations. Changing the Stretch value from 0 to 1 adds 1 clock cycle each to the data setup and hold times. When a Stretch value of 4 or above is selected, the interface timing changes dramatically to allow for very slow peripherals. First, the ALE signal is lengthened by 1 machine cycle. This increases the address setup time into the peripheral by this amount. Next, the address is held on the bus for one additional machine cycle increasing the address hold time by this amount. The \overline{WR} and \overline{RD} signals are then lengthened by a machine cycle. Finally, during a MOVX write the data is held on the bus for one additional machine cycle, thereby increasing the data hold time by this amount. For every Stretch value greater than 4, the setup and hold times remain constant, and only the width of the read or write signal is increased. These three gradations are reflected in the AC Electrical characteristics, where the eight MOVX timing specifications are represented by only three timing diagrams.

The reset default of one Stretch cycle results in a three cycle MOVX for any external access. Therefore, the default off-chip RAM access is not at full speed. This is a convenience to existing designs that utilize slower RAM. When maximum speed is desired, software should select a Stretch value of zero. When using very slow RAM or peripherals, the application software can select a larger Stretch value.

The specific timing of MOVX instructions as a function of Stretch settings is provided in the Electrical Specifications section of this data sheet. As an example, Table 8 shows the read and write strobe widths corresponding to each Stretch value.

DATA MEMORY CYCLE STRETCH VALUES Table 8

MD2	MD1	MD0	Stretch Cycle Count	MOVX Machine Cycles	RD, WR Pulse Width (in oscillator clocks)			
					t_{MCS} (4X/2X = 1 CD1:0 = 00)	t_{MCS} (4X/2X = 0 CD1:0 = 00)	t_{MCS} (4X/2X = X CD1:0 = 10)	t_{MCS} (4X/2X = X CD1:0 = 11)
0	0	0	0*	2	0.5 t_{CLCL}	1 t_{CLCL}	2 t_{CLCL}	2048 t_{CLCL}
0	0	1	1**	3	t_{CLCL}	2 t_{CLCL}	4 t_{CLCL}	4096 t_{CLCL}
0	1	0	2	4	2 t_{CLCL}	4 t_{CLCL}	8 t_{CLCL}	8192 t_{CLCL}
0	1	1	3	5	3 t_{CLCL}	6 t_{CLCL}	12 t_{CLCL}	12288 t_{CLCL}
1	0	0	4	9	4 t_{CLCL}	8 t_{CLCL}	16 t_{CLCL}	16384 t_{CLCL}
1	0	1	5	10	5 t_{CLCL}	10 t_{CLCL}	20 t_{CLCL}	20480 t_{CLCL}
1	1	0	6	11	6 t_{CLCL}	12 t_{CLCL}	24 t_{CLCL}	24576 t_{CLCL}
1	1	1	7	12	7 t_{CLCL}	14 t_{CLCL}	28 t_{CLCL}	28672 t_{CLCL}

*All internal MOVX operations execute at the 0 Stretch setting.

** Default Stretch setting for external MOVX operations following reset.

EXTENDED STACK POINTER

The DS80C390 supports both the traditional 8-bit and an extended 10-bit stack pointer that improves the performance of large programs written in high-level languages such as C. The 10-bit stack pointer feature is enabled by setting the Stack Address Mode bit, SA (ACON.2). The bit is cleared following a reset, forcing the device to use an 8-bit stack located in the Scratchpad RAM area. When the SA bit is set, the device will address up to 1kB of stack memory in the first 1kB of the internal MOVX memory. The 10-bit stack pointer address is generated by concatenating the lower two bits of the Extended Stack Pointer (ESP;9Bh) and the traditional 8051 Stack Pointer (SP;81h). The 10-bit stack pointer cannot be enabled when the 4kB of SRAM is mapped as both program and data memory.

ENHANCED DUAL DATA POINTERS

The DS80C390 contains two data pointers, DPTR0 and DPTR1, designed to improve performance in applications that require high data throughput. Incorporating a second data pointer allows the software to greatly speed up block data (MOVX) moves by using one data pointer as a source register and the other as the destination register.

DPTR0 is located at the same address as the original 8051 data pointer, allowing the DS80C390 to execute standard 8051 code with no modifications. The second data pointer, DPTR1, is split between the DPH1 and DPL1 SFRs, similar to the DPTR0 configuration. The active data pointer is selected with the data pointer select bit SEL (DPS.0). Any instructions that reference the DPTR (i.e., MOVX A, @DPTR), will select DPTR0 if SEL=0, and DPTR1 if SEL=1. Because the bits adjacent to SEL are not implemented, the state of SEL (and thus the active data pointer) can be quickly toggled by the INC DPS instruction without disturbing other bits in the DPS register.

Unlike the standard 8051, the DS80C390 has the ability to decrement as well as increment the data pointers without additional instructions. When the INC DPTR instruction is executed, the active DPTR increments or decrements according to the ID1, ID0 (DPS.7-6), and SEL (DPS.0) bits as shown. The inactive DPTR is not affected.

DATA POINTER AUTOINCREMENT/DECREMENT CONFIGURATION Table 9

ID1	ID0	SEL	Result of INC DPTR
X	0	0	Increment DPTR0
X	1	0	Decrement DPTR0
0	X	1	Increment DPTR1
1	X	1	Decrement DPTR1

Another useful feature of the device is its ability to automatically switch the active data pointer after a DPTR-based instruction is executed. This feature can greatly reduce the software overhead associated with data memory block moves, which toggle between the source and destination registers. When the Toggle Select bit (TSL;DPS.5) is set to 1, the SEL bit (DPS.0) is automatically toggled every time one of the following DPTR related instructions is executed.

```
INC DPTR
MOV DPTR, #data16
MOVC A, @A+DPTR
MOVX A, @DPTR
MOVX @DPTR, A
```

As a brief example, if TSL is set to 1, then both data pointers can be updated with two INC DPTR instructions. Assume that SEL=0, making DPTR the active data pointer. The first INC DPTR increments DPTR and toggles SEL to 1. The second instruction increments DPTR1 and toggles SEL back to 0.

```
INC DPTR
INC DPTR
```

CLOCK CONTROL AND POWER MANAGEMENT

The DS80C390 includes a number of unique features that allow flexibility in selecting system clock sources and operating frequencies. To support the use of inexpensive crystals while allowing full speed operation, a clock multiplier is included in the processor's clock circuit. Also, in addition to the standard

80C32 Idle and power down (Stop) modes, the DS80C390 provides a new Power Management Mode. This mode allows the processor to continue instruction execution, yet at a very low speed to significantly reduce power consumption (below even idle mode). The DS80C390 also features several enhancements to Stop mode that make this extremely low power mode more useful. Each of these features is discussed in detail below.

SYSTEM CLOCK CONTROL

As mentioned previously, the microcontroller contains special clock control circuitry that simultaneously provides maximum timing flexibility and maximum availability and economy in crystal selection. The logical operation of the system clock divide control function is shown in Figure 2. A 3:1 multiplexer, controlled by CD1, CD0 (PMR.7-6), selects one of three sources for the internal system clock:

- Crystal oscillator or external clock source
- (Crystal oscillator or external clock source) divided by 256
- (Crystal oscillator or external clock source) frequency multiplied by 2 or 4 times.

SYSTEM CLOCK CONTROL DIAGRAM Figure 2

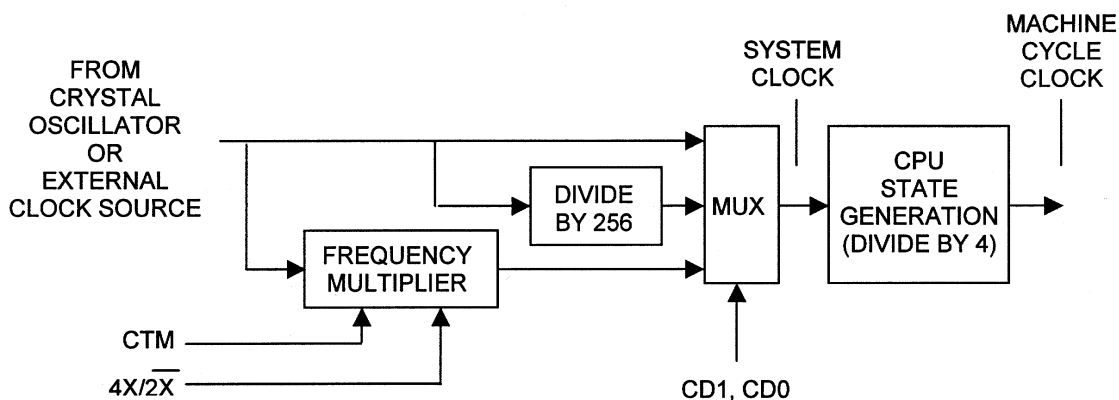

The system clock control circuitry generates two clock signals that are used by the microcontroller. The *internal system clock* provides the timebase for timers and internal peripherals. The system clock is run through a divide by 4 circuit to generate the *machine cycle clock* that provides the timebase for CPU operations. All instructions execute in one to five machine cycles. It is important to note the distinction between these two clock signals, as they are sometimes confused, creating errors in timing calculations.

Setting CD1, CD0 to 0 enables the frequency multiplier, either doubling or quadrupling the frequency of the crystal oscillator or external clock source. The $\overline{4X/2X}$ bit controls the multiplying factor, selecting twice or four times the frequency when set to 0 or 1, respectively. Enabling the frequency multiplier results in apparent instruction execution speeds of 2 or 1 clocks. Regardless of the configuration of the frequency multiplier, the system clock of the microcontroller can never be operated faster than 40 MHz. This means that the maximum crystal oscillator or external clock source is 10 MHz when using the 4X setting, and 20 MHz when using the 2X setting.

The primary advantage of the clock multiplier is that it allows the microcontroller to use slower crystals to achieve the same performance level. This reduces EMI and cost, as slower crystals are generally more available and thus less expensive.

SYSTEM CLOCK CONFIGURATION Table 10

CD1	CD0	$\overline{4X/2X}$	Name	Clocks/MC	Max. External Frequency
0	0	0	Frequency Multiplier (2X)	2	20 MHz
0	0	1	Frequency Multiplier (4X)	1	10 MHz
0	1	N/A	Reserved		
1	0	N/A	Divide-by-four (Default)	4	40 MHz
1	1	N/A	Power Management Mode	1024	40 MHz

The system clock and machine cycle rate changes one machine cycle after the instruction changing the control bits. Note that the change will affect all aspects of system operation, including timers and baud rates. The use of the switchback feature, described later, can eliminate many of the problems associated with the Power Management Mode.

Changing the system clock/machine cycle clock frequency

The microcontroller incorporates a special locking sequence to ensure “glitch-free” switching of the internal clock signals. All changes to the CD1, CD0 bits must pass through the 10 (divide-by-four) state. For example, to change from 00 (frequency multiplier) to 11 (PMM), the software must change the bits in the following sequence: 00 -> 10 -> 11. Attempts to switch between invalid states will fail, leaving the CD1, CD0 bits unchanged.

The following sequence must be followed when switching to the frequency multiplier as the internal time source. This sequence can only be performed when the device is in divide-by-four operation. The steps must be followed in this order, although it is possible to have other instructions between them. Any deviation from this order will cause the CD1, CD0 bits to remain unchanged. Switching from frequency multiplier to non-multiplier mode requires no steps other than the changing of the CD1, CD0 bits.

1. Ensure that the CD1, CD0 bits are set to 10, and the RGMD (EXIF.2) bit = 0.
2. Clear the CTM (Crystal Multiplier Enable) bit.
3. Set the $\overline{4X/2X}$ bit to the appropriate state.
4. Poll the CKRDY bit (PMR.4), waiting until it is set to 1. This will take approximately 65536 cycles of the external crystal or clock source.
5. Set CD1, CD0 to 00. The frequency multiplier will be engaged on the machine cycle following the write to these bits.

OSCILLATOR FAIL DETECT

The microprocessor contains a safety mechanism called an on-chip Oscillator Fail Detect circuit. When enabled, this circuit causes the processor to be held in reset if the oscillator frequency falls below TBD kHz. In operation, this circuit complements the Watchdog timer. Normally, the watchdog timer is initialized so that it will time-out and will cause a processor reset in the event that the processor loses control. In the event of a crystal or external oscillator failure, however, the watchdog timer will not function and there is the potential for the processor to fail in an uncontrolled and possible undesirable state. With the use of the oscillator fail detect circuit, the processor will be forced to a known state (i.e., reset) even if the oscillator stops.

The oscillator fail detect circuitry is enabled when software sets the enable bit OFDE (PCON.4) to a 1. Please note that software must use a “Timed Access” procedure (described later) to write this bit. The OFDF (PCON.5) bit will also be set to a 1 when the circuitry detects an oscillator failure, and the processor is forced into a reset state. This bit can only be cleared to a 0 by a power fail reset or by software. The oscillator fail detect circuitry will not be activated when the oscillator is stopped due to the processor entering Stop mode.

POWER MANAGEMENT MODE (PMM)

Crystal Speed	Machine Cycle Rate		Operating Current Estimates	
	Full Operation (4 clocks per machine cycle)	PMM (1024 clocks per machine cycle)	Full Operation (4 clocks per machine cycle)	PMM (1024 clocks per machine cycle)
11.0592 MHz	2.765 MHz	10.8 kHz	13.1 ma	4.8 ma
16 MHz	4.0 MHz	15.6 kHz	17.2 ma	5.6 ma
25 MHz	6.25 MHz	24.4 kHz	25.7 ma	7.0 ma
33 MHz	8.25 MHz	32.2 kHz	32.8 ma	8.2 ma
40 MHz	10.0 MHz	39.1 kHz	TBD	TBD

Note that power consumption in PMM is less than Idle mode. While both modes leave the power-hungry internal timers running, PMM runs all clocked functions such as timers at the rate of crystal divided by 1024, rather than crystal divided by 4. Even though instruction execution continues in PMM (albeit at a reduced speed), it still consumes less power than Idle mode. As a result there is little reason to use Idle mode in new designs.

SWITCHBACK

When enabled, the Switchback feature allows serial ports and interrupts to automatically switch back from divide by 1024 (PMM) to divide by 4 (standard speed) operation. This feature makes it very convenient to use the Power Management Mode in real-time applications. Software can simply set the CD1 and CD0 clock control bits to the 4 clocks per cycle mode to exit PMM. However, the microcontroller provides hardware alternatives for automatic Switchback to standard speed (divide by 4) operation.

The Switchback feature is enabled by setting the SFR bit SWB (PMR.5) to a 1. Once it is enabled, and when PMM is selected, two possible events can cause an automatic Switchback to divide by four mode. First, if an interrupt occurs and is acknowledged, the system clock will revert from PMM to divide by four mode. For example, if $\overline{\text{INT0}}$ is enabled and the CPU is not servicing a higher priority interrupt, then Switchback will occur on $\overline{\text{INT0}}$. However, if $\overline{\text{INT0}}$ is not enabled or the CPU is servicing a higher priority interrupt, then activity on $\overline{\text{INT0}}$ will not cause Switchback to occur.

A Switchback can also occur when an enabled UART detects the start bit indicating the beginning of an incoming serial character or when the SBUF register is loaded initiating a serial transmission. Note that a serial character's start bit does not generate an interrupt. The interrupt occurs only on reception of a complete serial word. The automatic Switchback on detection of a start bit allows timer hardware to return to divide by 4 operation (and the correct baud rate) in time for a proper serial reception or transmission. So with Switchback enabled and a serial port enabled, the automatic switch to divide by 4 operation occurs in time to receive or transmit a complete serial character as if nothing special had happened.

STATUS

The Status register (STATUS;C5h) provides information about interrupt and serial port activity to assist in determining if it is possible to enter PMM. The microprocessor supports three levels of interrupt priority: Power-fail, High, and Low. The PIP (Power-fail Priority Interrupt Status; STATUS.7), HIP (High Priority Interrupt Status; STATUS.6), and LIP (Low Priority Interrupt Status; STATUS.5) status bits, when set to a logic one, indicate the corresponding level is in service.

Software should not rely on a lower-priority level interrupt source to remove PMM (Switchback) when a higher level is in service. Check the current priority service level before entering PMM. If the current service level locks out a desired Switchback source, then it would be advisable to wait until this condition clears before entering PMM. Alternately, software can prevent an undesired exit from PMM by intentionally entering a low priority interrupt service level before entering PMM. This will prevent other low priority interrupts from causing a Switchback.

Entering PMM during an ongoing serial port transmission or reception can corrupt the serial port activity. To prevent this, a hardware lockout feature ignores changes to the clock divisor bits while the serial ports are active. Serial port activity can be monitored via the Serial Port Activity bits located in the Status register.

IDLE MODE

Setting the IDLE bit (PCON.0) invokes the Idle mode. Idle will leave internal clocks, serial ports and timers running. Power consumption drops because memory is not being accessed and instructions are not being executed. Since clocks are running, the Idle power consumption is a function of crystal frequency. It should be approximately $\frac{1}{2}$ of the operational power at a given frequency. The CPU can exit Idle mode with any interrupt or a reset. Because Power Management Mode (PMM) consumes less power than Idle mode, as well as leaving timers and CPU operating, Idle mode is no longer recommended for new designs, and is included for backward software compatibility only.

STOP MODE

Setting the STOP bit of the Power Control register (PCON.1) invokes Stop mode. Stop mode is the lowest power state (besides power off) since it turns off all internal clocking. The I_{CC} of a standard Stop mode is approximately 1 μ A (consult the Electrical Specifications section for full details). All processor operation ceases at the end of the instruction that sets the STOP Bit. The CPU can exit Stop mode via an external interrupt, if enabled, or a reset condition. Internally generated interrupts (timer, serial port, watchdog) cannot cause an exit from Stop mode because internal clocks are not active in Stop mode.

BAND-GAP SELECT

The DS80C390 provides two enhancements to Stop mode. As described below, the device provides a band-gap reference to determine Power-fail Interrupt and Reset thresholds. The band-gap reference is controlled by the Band-Gap Select bit, BGS (RCON.0). Setting BGS to a 1 will keep the band-gap reference enabled during Stop mode. The default or reset condition of the bit is logic 0, which disables the band-gap during Stop mode. This bit has no control of the reference during full power, PMM, or Idle modes.

With the band-gap reference enabled, the Power-fail reset and interrupt are valid means for leaving Stop mode. This allows software to detect and compensate for a power supply sag or brownout, even when in Stop mode. In Stop mode with the band-gap enabled, I_{CC} will be approximately 100 μ A compared with 1 μ A with the band-gap disabled. If a user does not require a Power-fail Reset or Interrupt while in Stop mode, the band-gap can remain disabled. Only the most power sensitive applications should disable the band-gap reference in Stop mode, as this results in an uncontrolled power down condition.

RING OSCILLATOR

The second enhancement to Stop mode reduces power consumption and allows the device to restart instantly when exiting Stop mode. The ring oscillator is an internal clock that can optionally provide the clock source to the microcontroller when exiting Stop mode in response to an interrupt.

During Stop mode the crystal oscillator is halted to maximize power savings. Typically 4 - 10 ms are required for an external crystal to begin oscillating again once the device receives the exit stimulus. The ring oscillator, by contrast, is a free-running digital oscillator that has no startup delay. The ring oscillator feature is enabled by setting the Ring Oscillator Select bit, RGSL (EXIF.1). If enabled, the microcontroller uses the ring oscillator as the clock source to exit Stop mode, resuming operation in less than 100 ns. After 65536 oscillations of the external clock source (not the ring oscillator), the device will clear the Ring Oscillator Mode bit, RGMD (EXIF.2) to indicate that the device has switched from the ring oscillator to the external clock source.

The ring oscillator runs at approximately 10 MHz, but varies over temperature and voltage. As a result, no serial communication or precision timing should be attempted while running from the ring oscillator since the operating frequency is not precise. The default state exits Stop mode without using the ring oscillator.

TIMED ACCESS PROTECTION

Selected SFR bits are critical to operation, making it desirable to protect them against an accidental write operation. The Timed Access procedure prevents an errant processor from accidentally altering bits that would seriously affect processor operation. The Timed Access procedure requires that the write of a protected bit be immediately preceded by the following two instructions:

```
MOV 0C7h, #0AAh
MOV 0C7h, #55h
```

Writing an AAh followed by a 55h to the Timed Access register (location C7h), opens a three-cycle window that allows software to modify one of the protected bits. If the instruction that seeks to modify the protected bit is not immediately preceded by these instructions, the write will be ignored. The protected bits are:

WDCON.6	POR	Power-On Reset Flag
WDCON.3	WDIF	Watchdog Interrupt Flag
WDCON.1	EWT	Watchdog Reset Enable
WDCON.0	RWT	Reset Watchdog Timer
RCON.0	BGS	Band-Gap Select
ACON.2	SA	Stack Address Mode
ACON.1-0	AM1-AM0	Address Mode Select bits
MCON.7-6	IDM1-IDM0	Internal Memory Configuration and Location bits
MCON.5	CMA	CAN Data Memory Assignment
MCON.3-0	PDCE3-PDCE.0	Program/Data Chip Enables
C0C.3	CRST	CAN 0 Reset
C1C.3	CRST	CAN 1 Reset
P4CNT.6	SBCAN	Single Bus CAN
P4CNT.5-0		Port 4 Pin Configuration Control Bits
P5CNT.2-0	P5.7-P5.5	Configuration Control Bits
COR.7	IRDACK	IRDA Clock Output Enable
COR.6-5	C1BPR7-C1BPR6	CAN 1 Baud Rate Pre-scale Bits
COR.4-3	C0BPR7-C0BPR6	CAN 0 Baud Rate Pre-scale Bits
COR.2-1	COD1-COD0	CAN Clock Output Divide Bit 1 and Bit 0
COR.0	CLKOE	CAN Clock Output Enable

EMI REDUCTION

One of the major contributors to radiated noise in an 8051-based system is the toggling of ALE. The microcontroller allows software to disable ALE when not used by setting the ALEOFF (PMR.2) bit to a 1. When ALEOFF = 1, ALE will automatically toggle during an off-chip MOVX. However, ALE will remain static when performing on-chip memory access. The default state of ALEOFF is 0 so ALE normally toggles at a frequency of XTAL/4.

PERIPHERAL OVERVIEW

The DS80C390 provides several of the most commonly needed peripheral functions in microcomputer-based systems. New functions include a second serial port, power-fail reset, power-fail interrupt flag, and a programmable watchdog timer. In addition, the microcontroller contains two Controller Area Network (CAN) modules for industrial communication applications. Each of these peripherals is described below, and more details are available in the User's Guide.

SERIAL PORTS

The microcontroller provides a serial port (UART) that is identical to the 80C52. In addition it includes a second hardware serial port that is a full duplicate of the standard one. This second port optionally uses pins P1.2 (RXD1) and P1.3 (TXD1). It has duplicate control functions included in new SFR locations.

Both ports can operate simultaneously but can be at different baud rates or even in different modes. The second serial port has similar control registers (SCON1, SBUF1) to the original. The new serial port can only use Timer 1 for baud rate generation.

The SCON0 register provides control for serial port 0 while its I/O buffer is SBUF0. The registers SCON1 and SBUF1 provide the same functions for the second serial port. A full description on the use and operation of both serial ports may be found in the User's Guide.

WATCHDOG TIMER

The Watchdog is a free running, programmable timer that can set a flag, cause an interrupt, and/or reset the microcontroller if allowed to reach a preselected time-out. It can be restarted by software.

A typical application uses the watchdog timer as a reset source to prevent software from losing control. The watchdog timer is initialized, selecting the time-out period and enabling the reset and/or interrupt functions. After enabling the reset function, software must then restart the timer before its expiration or hardware will reset the CPU. In this way if the code execution goes awry and software does not reset the watchdog as scheduled, the processor is put in a known good state: reset.

Software can select one of four time-out values as controlled by the WD1 and WD0 bits. Time-out values are precise since they are a function of the crystal frequency. When the Watchdog times out, it sets the Watchdog Timer Reset Flag (WTRF=WDCON.2) which generates a reset if enabled by the Enable Watchdog Timer Reset (EWT=WDCON.1) bit. Both the Enable Watchdog Timer Reset and the Reset Watchdog Timer control bits are protected by "Timed Access" circuitry. This prevents errant software from accidentally clearing or disabling the Watchdog.

The Watchdog interrupt is useful for systems that do not require a reset circuit. It will set the WDIF (Watchdog interrupt) flag 512 clocks before setting the reset flag. Software can optionally enable this interrupt source, which is independent of the watchdog reset function. The interrupt is common used during the debug process to determine where watchdog reset commands must be located in the

application software. The interrupt also can serve as a convenient time-base generator or can wake-up the processor from power saving modes.

The Watchdog timer is controlled by the Clock Control (CKCON) and the Watchdog Control (WDCON) SFRs. CKCON.7 and CKCON.6 are WD1 and WD0 respectively, and they select the Watchdog time-out period. Of course, the $4X/2X$ (PMR.3) and CD1:0 (PMR.7:6) system clock control bits also affect the time-out period. Selection of time-out is shown below.

WATCHDOG TIME-OUT VALUES Table 11

$4X/2X$	CD1:0	WATCHDOG INTERRUPT TIME-OUT				WATCHDOG RESET TIME-OUT			
		WD1:0=00	WD1:0=01	WD1:0=10	WD1:0=11	WD1:0=00	WD1:0=01	WD1:0=10	WD1:0=11
1	00	2^{15}	2^{18}	2^{21}	2^{24}	$2^{15}+512$	$2^{18}+512$	$2^{21}+512$	$2^{24}+512$
0	00	2^{16}	2^{19}	2^{22}	2^{25}	$2^{16}+512$	$2^{19}+512$	$2^{22}+512$	$2^{25}+512$
x	01	2^{17}	2^{20}	2^{23}	2^{26}	$2^{17}+512$	$2^{20}+512$	$2^{23}+512$	$2^{26}+512$
x	10	2^{17}	2^{20}	2^{23}	2^{26}	$2^{17}+512$	$2^{20}+512$	$2^{23}+512$	$2^{26}+512$
x	11	2^{25}	2^{28}	2^{31}	2^{34}	$2^{25}+512$	$2^{28}+512$	$2^{31}+512$	$2^{34}+512$

The table demonstrates that for a 33 MHz crystal frequency the Watchdog timer is capable of producing time-out periods from 3.97 ms ($2^{17} * 1/33$ MHz) to over two seconds ($2.034 = 2^{26} * 1/33$ MHz) with the default setting of CD1:0 (=10). This wide variation in time-out periods allows very flexible system implementation.

In a typical initialization, the user selects one of the possible counter values to determine the time-out. Once the counter chain has completed a full count, hardware will set the interrupt flag (WDIF=WDCON.3). Regardless of whether the software makes use of this flag, there are then 512 clocks left until the reset flag (WTRF=WDCON.2) is set. Software can enable (1) or disable (0) the reset using the Enable Watchdog Timer Reset (EWT=WDCON.1) bit.

POWER FAIL RESET

The microcontroller incorporates an internal precision band-gap voltage reference and comparator circuit which provide a power-on and power-fail reset function. This circuit monitors the processor's incoming power supply voltage (V_{CC}), and holds the processor in reset while V_{CC} is below the minimum voltage level. When power exceeds the reset threshold, a full power-on reset will be performed. In this way, this internal voltage monitoring circuitry handles both power-up and power-down conditions without the need for additional external components.

Once V_{CC} has risen above V_{RST} , the device will automatically restart the oscillator for the external crystal and count 65,536 clock cycles before program execution begins at location 0000h. This helps the system maintain reliable operation by only permitting processor operation when the supply voltage is in a known good state. Software can determine that a power-on reset has occurred by checking the Power-On Reset flag (POR=WDCON.6). Software should clear the POR bit after reading it.

The DS80C390 has both reset input (RST) and reset output (\overline{RSTOL}) pins. The \overline{RSTOL} pin supplies an active low Reset when the microprocessor is issued a Reset from either a high on the RST pin, a time out of the watchdog time, a crystal oscillator fail, or an internally detected power-fail.

POWER FAIL INTERRUPT

The band-gap voltage reference that sets a precise reset threshold also generates an optional early warning Power-fail Interrupt (PFI). When enabled by software, the processor will vector to ROM address 0033h if V_{CC} drops below V_{PFW} . PFI has the highest priority. The PFI enable is in the Watchdog Control SFR

(EPFI;WDCON.5). Setting this bit to logic 1 will enable the PFI. Application software can also read the PFI flag at WDCON.4. A PFI condition sets this bit to a 1. The flag is independent of the interrupt enable and must be cleared by software.

INTERRUPTS

The microcontroller provides 16 interrupt sources with three priority levels. All interrupts, with the exception of the Power Fail interrupt, are controlled by a series combination of individual enable bits and a global interrupt enable EA (IE.7). Setting EA to a 1 allows individual interrupts to be enabled. Clearing EA disables all interrupts regardless of their individual enable settings.

The three available priority levels are low, high, and highest. The highest priority level is reserved for the Power Fail Interrupt only. All other interrupt priority levels have individual priority bits that when set to a 1 establish the particular interrupt as high priority. In addition to the user-selectable priorities, each interrupt also has an inherent natural priority, used to determine the priority of simultaneously occurring interrupts. The available interrupt sources, their flags, their enables, their natural priority, and their available priority selection bits are identified in the following table.

INTERRUPT SUMMARY Table 12

NAME	DESCRIPTION	VECTOR	NATURAL PRIORITY	FLAG BIT	ENABLE BIT	PRIORITY CONTROL BIT
PFI	Power Fail Interrupt	33h	0	PFI(WDCON.4)	EPFI(WDCON.5)	N/A
INT0	External Interrupt 0	03h	1	IE0(TCON.1)**	EX0(IE.0)	PX0(IP.0)
TF0	Timer 0	0Bh	2	TF0(TCON.5)*	ET0(IE.1)	PT0(IP.1)
INT1	External Interrupt 1	13h	3	IE1(TCON.3)**	EX1(IE.2)	PX1(IP.2)
TF1	Timer 1	1Bh	4	TF1(TCON.7)*	ET1(IE.3)	PT1(IP.3)
SCON0	TI0 or RI0 from serial port 0	23h	5	RI_0(SCON0.0) TI_0(SCON0.1)	ES0(IE.4)	PS0(IP.4)
TF2	Timer 2	2Bh	6	TF2(T2CON.7)	ET2(IE.5)	PT2(IP.7)
SCON1	TI1 or RI1 from serial port 1	3Bh	7	RI_1(SCON1.0) TI_1(SCON1.1)	ES1(IE.6)	PS1(IP.6)
INT2	External Interrupt 2	43h	8	IE2 (EXIF.4)	EX2 (EIE.0)	PX2 (EIP.0)
INT3	External Interrupt 3	4Bh	9	IE3 (EXIF.5)	EX3 (EIE.1)	PX3 (EIP.1)
INT4	External Interrupt 4	53h	10	IE4 (EXIF.6)	EX4 (EIE.2)	PX4 (EIP.2)
INT5	External Interrupt 5	5Bh	11	IE5 (EXIF.7)	EX5 (EIE.3)	PX5 (EIP.3)
C0I	CAN0 Interrupt	6Bh	12	various	C0IE (EIE.6)	C0IP (EIP.6)
C1I	CAN1 Interrupt	73h	13	various	C1IE (EIE.5)	C1IP (EIP.5)
WDTI	Watchdog Timer	63h	14	WDIF (WDCON.3)	EWDI (EIE.4)	PWDI (EIP.4)
CANBUS	CAN0/1 Bus Activity	7Bh	15	various	CANBIE (EIE.7)	CANBIP (EIP.7)

Unless marked, all flags must be cleared by the application software.

* Cleared automatically by hardware when the service routine is entered.

** If edge triggered, flag is cleared automatically by hardware when the service routine is entered. If level triggered, flag follows the state of the interrupt pin.

CONTROLLER AREA NETWORK (CAN) MODULE

The DS80C390 incorporates two CAN controllers that are fully compliant with the CAN 2.0B specification. CAN is a highly robust, high-performance communication protocol for serial communications. Popular in a wide range of applications including automotive, medical, heating, ventilation, and industrial control, the CAN architecture allows for the construction of sophisticated networks with a minimum of external hardware.

The CAN controllers support the use of 11-bit standard or 29-bit extended acceptance identifiers for up to 15 messages, with the standard 8 byte data field, in each message. Fourteen of the fifteen message

centers are programmable in either transmit or receive modes, with the fifteenth designated as a FIFO-buffered, receive-only message center to help prevent data overruns. All message centers support two separate 8-bit media masks and media arbitration fields for incoming message verification. This feature supports the use of higher level protocols which make use of the first and/or second byte of data as a part of the acceptance layer for storing incoming messages. Each message center can also be programmed independently to test incoming data with or without the use of the global masks.

Global controls and status registers in each CAN unit allow the microcontroller to evaluate error messages, generate interrupts, locate and validate new data, establish the CAN Bus timing, establish identification mask bits, and verify the source of individual messages. Each message center is individually equipped with the necessary status and control bits to establish direction, identification mode (standard or extended), data field size, data status, automatic remote frame request and acknowledgment, and perform masked or non-masked identification acceptance testing.

COMMUNICATING WITH THE CAN MODULE

The microcontroller interface to the CAN modules is divided into two groups of registers. All of the global CAN status and control bits as well as the individual message center control/status registers are located in the Special Function Register map. The remaining registers associated with the message centers (data identification, identification/arbitration masks, format and data) are located in MOVX data space. The CMA bit (MCON.5) allows the message centers to select one of two MOVX addresses, reducing the possibility of a memory conflict with application software. A special lockout feature prevents the accidental software corruption of the control, status and mask registers while a CAN operation is in progress. Each CAN processor utilizes a total of 15 message centers. Each message center is composed of four specific areas. These include:

1. Four arbitration registers (C0MxAR0-3 and C1MxAR0-3) which store either the 11-bit or 29-bit arbitration value. These registers are located in the MOVX memory map.
2. A Format Register (C0MxF and C1MxF) which informs the CAN processor as to the direction (transmit or receive), the number of data bytes in the message, the Identification Format (standard or extended), and the optional use of the Identification Mask or Media Mask during message evaluation. This register is located in the MOVX memory map.
3. Eight data bytes for storage of 0 - 8 bytes of data (C0MxD0-7 and C1MxD0-7) are located in the MOVX memory map.
4. Message Control Registers (C0MxC and C1MxC) are located in the SFR memory for fast access.

Each of the message centers is identical with the exception of message center 15. Message center 15 has been designed as a receive only center and is also buffered through the use of a two message FIFO to help prevent message loss in a message overrun situation. The receipt of a third message before either of the first two are read will overwrite the second message, leaving the first message undisturbed.

Modification of the CAN registers located in MOVX memory is protected via the SWINT bits, with one bit protecting each respective CAN module. Consult the description of this bit in the User's Guide for more information. Each CAN Module contains a block of Control/Status/Mask registers, 14 functionally identical message centers, plus a fifteenth message center which is receive only and incorporates a buffered FIFO. The following tables describe the organization of the message centers located in MOVX space.

MOVX MESSAGE CENTERS FOR CAN 0**CAN 0 CONTROL/STATUS/MASK REGISTERS**

Register	7	6	5	4	3	2	1	0	MOVX Data Address¹
C0MID0	MID07	MID06	MID05	MID04	MID03	MID02	MID01	MID00	xxxx00h
C0MA0	M0AA7	M0AA6	M0AA5	M0AA4	M0AA3	M0AA2	M0AA1	M0AA0	xxxx01h
C0MID1	MID17	MID16	MID15	MID14	MID13	MID12	MID11	MID10	xxxx02h
C0MA1	M1AA7	M1AA6	M1AA5	M1AA4	M1AA3	M1AA2	M1AA1	M1AA0	xxxx03h
C0BT0	SJW1	SJW0	BPR5	BPR4	BPR3	BPR2	BPR1	BPR0	xxxx04h
C0BT1	SMP	TSEG26	TSEG25	TSEG24	TSEG13	TSEG12	TSEG11	TSEG10	xxxx05h
C0SGM0	ID28	ID27	ID26	ID25	ID24	ID23	ID22	ID21	xxxx06h
C0SGM1	ID20	ID19	ID18	_2	_2	_2	_2	_2	xxxx07h
C0EGM0	ID28	ID27	ID26	ID25	ID24	ID23	ID22	ID21	xxxx08h
C0EGM1	ID20	ID19	ID18	ID17	ID16	ID15	ID14	ID13	xxxx09h
C0EGM2	ID12	ID11	ID10	ID9	ID8	ID7	ID6	ID5	xxxx0Ah
C0EGM3	ID4	ID3	ID2	ID1	ID0	_2	_2	_2	xxxx0Bh
C0M15M0	ID28	ID27	ID26	ID25	ID24	ID23	ID22	ID21	xxxx0Ch
C0M15M1	ID20	ID19	ID18	ID17	ID16	ID15	ID14	ID13	xxxx0Dh
C0M15M2	ID12	ID11	ID10	ID9	ID8	ID7	ID6	ID5	xxxx0Eh
C0M15M3	ID4	ID3	ID2	ID1	ID0	_2	_2	_2	xxxx0Fh

CAN 0 MESSAGE CENTER 1

	Reserved								xxxx10h - 11h
C0M1AR0	CAN 0 MESSAGE 1 ARBITRATION REGISTER 0								xxxx12h
C0M1AR1	CAN 0 MESSAGE 1 ARBITRATION REGISTER 1								xxxx13h
C0M1AR2	CAN 0 MESSAGE 1 ARBITRATION REGISTER 2								xxxx14h
C0M1AR3	CAN 0 MESSAGE 1 ARBITRATION REGISTER 3							WTOE	xxxx15h
C0M1F	DTBYC3	DTBYC2	DTBYC1	DTBYC0	T/R	EX/ST	MEME	MDME	xxxx16h
C0M1D0-7	CAN 0 MESSAGE 1 DATA BYTES 0 - 7								xxxx17h - 1Eh
	Reserved								xxxx1Fh

CAN 0 MESSAGE CENTERS 2-14

	MESSAGE CENTER 2 REGISTERS (similar to Message Center 1)	xxxx20h - 2Fh
	MESSAGE CENTER 3 REGISTERS (similar to Message Center 1)	xxxx30h - 3Fh
	MESSAGE CENTER 4 REGISTERS (similar to Message Center 1)	xxxx40h - 4Fh
	MESSAGE CENTER 5 REGISTERS (similar to Message Center 1)	xxxx50h - 5Fh
	MESSAGE CENTER 6 REGISTERS (similar to Message Center 1)	xxxx60h - 6Fh
	MESSAGE CENTER 7 REGISTERS (similar to Message Center 1)	xxxx70h - 7Fh
	MESSAGE CENTER 8 REGISTERS (similar to Message Center 1)	xxxx80h - 8Fh
	MESSAGE CENTER 9 REGISTERS (similar to Message Center 1)	xxxx90h - 9Fh
	MESSAGE CENTER 10 REGISTERS (similar to Message Center 1)	xxxxA0h - AFh
	MESSAGE CENTER 11 REGISTERS (similar to Message Center 1)	xxxxB0h - BFh
	MESSAGE CENTER 12 REGISTERS (similar to Message Center 1)	xxxxC0h - CFh
	MESSAGE CENTER 13 REGISTERS (similar to Message Center 1)	xxxxD0h - DFh
	MESSAGE CENTER 14 REGISTERS (similar to Message Center 1)	xxxxE0h - EFh

CAN 0 MESSAGE CENTER 15

-	Reserved							xxxxF0h - F1h	
COM15AR0	CAN 0 MESSAGE 15 ARBITRATION REGISTER 0							xxxxF2h	
COM15AR1	CAN 0 MESSAGE 15 ARBITRATION REGISTER 1							xxxxF3h	
COM15AR2	CAN 0 MESSAGE 15 ARBITRATION REGISTER 2							xxxxF4h	
COM15AR3	CAN 0 MESSAGE 15 ARBITRATION REGISTER 3					WTOE	xxxxF5h		
COM15F	DTBYC3	DTBYC2	DTBYC1	DTBYC0	⁻²	EX/ST	MEME	MDME	xxxxF6h
COM15D0- COM15D7	CAN 0 MESSAGE 15 DATA BYTE 0 - 7							xxxxF7h - FEh	
	Reserved							xxxxFFh	

Notes:

¹The first two bytes of the CAN 0 MOVX memory address are dependent on the setting of the CMA bit (MCON.5) CMA=0, xxxx=00EE; CMA=1, xxxx=4010.

²Unused bits in the MOVX message centers will be indeterminate following a power-on reset, and afterwards retain the value of any data written to them.

MOVX MESSAGE CENTERS FOR CAN 1**CAN 1 CONTROL/STATUS/MASK REGISTERS**

Register	7	6	5	4	3	2	1	0	MOVX Data Address ¹
C1MID0	MID07	MID06	MID05	MID04	MID03	MID02	MID01	MID00	xxxx00h
C1MA0	M0AA7	M0AA6	M0AA5	M0AA4	M0AA3	M0AA2	M0AA1	M0AA0	xxxx01h
C1MID1	MID17	MID16	MID15	MID14	MID13	MID12	MID11	MID10	xxxx02h
C1MA1	M1AA7	M1AA6	M1AA5	M1AA4	M1AA3	M1AA2	M1AA1	M1AA0	xxxx03h
C1BT0	SJW1	SJW0	BPR5	BPR4	BPR3	BPR2	BPR1	BPR0	xxxx04h
C1BT1	SMP	TSEG26	TSEG25	TSEG24	TSEG13	TSEG12	TSEG11	TSEG10	xxxx05h
C1SGM0	ID28	ID27	ID26	ID25	ID24	ID23	ID22	ID21	xxxx06h
C1SGM1	ID20	ID19	ID18	- ²	- ²	- ²	- ²	- ²	xxxx07h
C1EGM0	ID28	ID27	ID26	ID25	ID24	ID23	ID22	ID21	xxxx08h
C1EGM1	ID20	ID19	ID18	ID17	ID16	ID15	ID14	ID13	xxxx09h
C1EGM2	ID12	ID11	ID10	ID9	ID8	ID7	ID6	ID5	xxxx0Ah
C1EGM3	ID4	ID3	ID2	ID1	ID0	- ²	- ²	- ²	xxxx0Bh
C1M15M0	ID28	ID27	ID26	ID25	ID24	ID23	ID22	ID21	xxxx0Ch
C1M15M1	ID20	ID19	ID18	ID17	ID16	ID15	ID14	ID13	xxxx0Dh
C1M15M2	ID12	ID11	ID10	ID9	ID8	ID7	ID6	ID5	xxxx0Eh
C1M15M3	ID4	ID3	ID2	ID1	ID0	- ²	- ²	- ²	xxxx0Fh

CAN 1 MESSAGE CENTER 1

	Reserved								xxxx10h - 11h
C1M1AR0	CAN 1 MESSAGE 1 ARBITRATION REGISTER 0								xxxx12h
C1M1AR1	CAN 1 MESSAGE 1 ARBITRATION REGISTER 1								xxxx13h
C1M1AR2	CAN 1 MESSAGE 1 ARBITRATION REGISTER 2								xxxx14h
C1M1AR3	CAN 1 MESSAGE 1 ARBITRATION REGISTER 3							WTOE	xxxx15h
C1M1F	DTBYC3	DTBYC2	DTBYC1	DTBYC0	T/R	EX/ST	MEME	MDME	xxxx16h
C1M1D0-7	CAN 1 MESSAGE 1 DATA BYTES 0 - 7								xxxx17h - 1Eh
	Reserved								xxxx1Fh

CAN 1 MESSAGE CENTERS 2-14

	MESSAGE CENTER 2 REGISTERS (similar to Message Center 1)	xxxx20h - 2Fh
	MESSAGE CENTER 3 REGISTERS (similar to Message Center 1)	xxxx30h - 3Fh
	MESSAGE CENTER 4 REGISTERS (similar to Message Center 1)	xxxx40h - 4Fh
	MESSAGE CENTER 5 REGISTERS (similar to Message Center 1)	xxxx50h - 5Fh
	MESSAGE CENTER 6 REGISTERS (similar to Message Center 1)	xxxx60h - 6Fh
	MESSAGE CENTER 7 REGISTERS (similar to Message Center 1)	xxxx70h - 7Fh
	MESSAGE CENTER 8 REGISTERS (similar to Message Center 1)	xxxx80h - 8Fh
	MESSAGE CENTER 9 REGISTERS (similar to Message Center 1)	xxxx90h - 9Fh
	MESSAGE CENTER 10 REGISTERS (similar to Message Center 1)	xxxxA0h - AFh
	MESSAGE CENTER 11 REGISTERS (similar to Message Center 1)	xxxxB0h - BFh
	MESSAGE CENTER 12 REGISTERS (similar to Message Center 1)	xxxxC0h - CFh
	MESSAGE CENTER 13 REGISTERS (similar to Message Center 1)	xxxxD0h - DFh
	MESSAGE CENTER 14 REGISTERS (similar to Message Center 1)	xxxxE0h - EFh

CAN 1 MESSAGE CENTER 15

-	Reserved								xxxxF0h - F1h
C1M15AR0	CAN 1 MESSAGE 15 ARBITRATION REGISTER 0								xxxxF2h
C1M15AR1	CAN 1 MESSAGE 15 ARBITRATION REGISTER 1								xxxxF3h
C1M15AR2	CAN 1 MESSAGE 15 ARBITRATION REGISTER 2								xxxxF4h
C1M15AR3	CAN 1 MESSAGE 15 ARBITRATION REGISTER 3						WTOE		xxxxF5h
C1M15F	DTBYC3	DTBYC2	DTBYC1	DTBYC0	- ²	EX/ST	MEME	MDME	xxxxF6h
C1M15D0- C1M15D7	CAN 1 MESSAGE 15 DATA BYTE 0 - 7								xxxxF7h - FEh
	Reserved								xxxxFFh

Notes:

¹The first two bytes of the CAN 1 MOVX memory address are dependent on the setting of the CMA bit (MCON.5) CMA=0, xxxx=00EF; CMA=1, xxxx=4011.

²Unused bits in the MOVX message centers will be indeterminate following a power-on reset, and afterwards retain the value of any data written to them.

CAN INTERRUPTS

The DS80C390 supports 3 interrupts associated with the CAN controllers. One interrupt is dedicated to each CAN controller, providing receive/transmit acknowledgments from each of its 15 message centers. The remaining interrupt, the Can Bus Activity Interrupt, is used to detect CAN bus activity on the C0RX or C1RX pins.

The message center interrupts are enabled/disabled by individual ETI (transmit) and ERI (receive) enable bits in the corresponding Message Control Register (located in SFR memory) for each message center. All of the message center interrupts of each CAN module are ORed together into their respective CAN interrupt. The successful transmission or receipt of a message will set the INTRQ bit in the corresponding Message Control Register (located in SFR memory). This bit can only be cleared via software. In addition, the Global Interrupt Enable bit (IE.7) and the specific CAN Interrupt Enable bit, EIE.6 (CAN0) or EIE.5 (CAN1) must be correctly set to acknowledge a message center interrupt.

Interrupt assertion of error and status conditions associated with the CAN modules is controlled by the ERIE and STIE bits located in the CAN Control registers, C0C and C1C.

ARBITRATION AND MASKING

After a CAN module has ascertained that an incoming message is bit error-free, the identification field of that message is then compared against one or more arbitration values to determine if they will be loaded into a message center. Each enabled message center (see the MSRDY bit in the CAN Message Control Register) is tested in order from 1-15. The first message center to successfully pass the test will receive the incoming message and end the testing. The use of masking registers allows the use of more complex identification schemes, as tests can be made based on bit patterns rather than an exact match between all bits in the identification field and arbitration values. Each CAN processor also incorporates a set of five masks to allow messages with different IDs to be grouped and successfully loaded into a message center;

Note that some of these masks are optional as per the bits shown in the Arbitration/Masking Feature Summary table.

There are several possible arbitration tests, varying according to which message center is involved. If all of the enabled tests succeed, the message is loaded into the respective message center. The most basic test, performed on all messages, compares either 11 (CAN 2.0A) or 29 (CAN 2.0B) bits of the identification field to the appropriate arbitration register, based on the EX/ST bit in the CAN 0/1 Format Register. The MEME bit (C0MxF.1 or C1MxF.1) controls whether the arbitration and ID registers are compared directly or via a mask register. A special set of arbitration registers dedicated to Message center 15 allow added flexibility in filtering this location.

If desired, further arbitration can be performed by comparing the first two bytes of the data field in each message against two 8-bit Media Arbitration register bytes. The MDME bit in the CAN Message Center Format Registers (C0MxF.0 or C1MxF.0) either disables (MDME=0) arbitration, or enables (MDME=1) arbitration using the Media ID Mask Registers 0-1.

If the 11-bit or 29-bit arbitration and the optional Media Byte arbitration are successful the message is loaded into the respective message center. The Format Register also allows the microcontroller to program each message center to function in a receive or transmit mode via the T/R bit and to use from 0 to 8 data bytes within the data field of a message. Note that Message Center 15 can only be used in a receive mode. To avoid a priority inversion the DS80C390 CAN processors are configured to reload the transmit buffer with the message of the highest priority (lowest message center number) whenever an arbitration is lost or an error condition occurs.

ARBITRATION/MASKING FEATURE SUMMARY Table 13

Test Name	Arbitration Registers	Mask Registers	Control bits and conditions
Standard 11-bit arbitration (CAN 2.0A)	Message Center Arbitration Registers 0-1 (Located in each Message Center, MOVX memory)	Standard Global Mask Registers 0-1 (Located in each CAN Control/Status/Mask Register bank, MOVX memory)	EX/ST =0 MEME=0: Mask register ignored. ID and arbitration register must match exactly. MEME=1: Only bits corresponding to 1 in mask register are compared in ID and arbitration registers.
Extended 29-bit arbitration (CAN 2.0B)	Message Center Arbitration Registers 0-3 (Located in each Message Center, MOVX memory)	Extended Global Mask Registers 0-3 (Located in each CAN Control/Status/Mask Register bank, MOVX memory)	EX/ST =1 MEME=0: Mask register ignored. ID and arbitration register must match exactly. MEME=1: Only bits corresponding to 1 in mask register are compared in ID and arbitration registers.
Media byte arbitration	Media Arbitration Registers 0-3 (Located in each CAN Control/Status/Mask Register bank, MOVX memory)	Media ID Mask Registers 0-1 (Located in each CAN Control/Status/Mask Register bank, MOVX memory)	MDME=0: Media byte arbitration disabled. MDME =1: Only bits corresponding to 1 in Media ID mask register are compared between data bytes 1 and 2 and Media arbitration registers.
Message Center 15, Standard 11-bit arbitration (CAN 2.0A)	Message Center 15 Arbitration Registers 0-1 (Located in Message Center 15, MOVX memory)	Message Center 15 Mask Registers 0-1 (Located in each CAN Control/Status/Mask Register bank, MOVX memory)	EX/ST =0 MEME=0: Mask register ignored. ID and arbitration register must match exactly. MEME=1: Message center 15 mask registers are ANDed with Global Mask register. Only bits corresponding to 1 in resulting value are compared in ID and arbitration registers.

Message Center 15, Extended 29-bit arbitration (CAN 2.0B)	Message Center 15 Arbitration Registers 0-3 (Located in Message Center 15, MOVX memory)	Message Center 15 Mask Registers 0-3 (Located in each CAN Control/Status/Mask Register bank, MOVX memory)	EX/ST =1 MEME=0: Mask register ignored. ID and arbitration register must match exactly. MEME=1: Message center 15 mask registers are ANDed with Global Mask register. Only bits corresponding to 1 in resulting value are compared in ID and arbitration registers.
---	---	---	---

MESSAGE BUFFERING/OVERWRITE

If a message center is configured for reception ($T/R=0$) and the previous message has not been read ($DTUP=1$), then the disposition of an incoming message to that message center will be controlled by the WTOE bit (located in CAN Arbitration Register 3 of each message center). When $WTOE=0$, the incoming message will be discarded and the current message untouched.

If the WTOE bit is set, the incoming message will be received and written over the existing data bytes in that message center. The Receiver Overwrite bit (ROW) will also be set in the corresponding Message Center Control Register, located in SFR memory.

Message center 15 is unique in that it incorporates a buffer that can receive up to two messages without loss. If a message is received by message center 15 while it contains an unread message, the new incoming message is held in an internal buffer. When the CAN processor reads the message center 15 memory location and then clears $DTUP=INTRQ=EXTRQ=0$, the contents of the internal buffer will automatically be loaded into the message center 15 MOVX memory location.

The message center 15 WTOE bit controls what happens if a third message is received when both the message center 15 MOVX memory location and the buffer contain unread messages. If $WTOE=0$, the new message will be discarded, leaving the message center 15 MOVX memory location and the buffer untouched. If $WTOE=1$, then the third message will write over the buffered message but leave the message center 15 MOVX memory location untouched.

ERROR COUNTER INTERRUPT GENERATION

Each CAN module can be independently configured to alert the microprocessor when either 96 or 128 errors have been detected by the transmit or receive error counters. The Error Count Select bit, ERCS (C0C.1 or C1C.1) selects whether the limit is 96 ($ERCS=0$) or 128 ($ERCS=1$) errors. When the error limit is exceeded, the CAN Error Count Exceeded bit, CECE (C0S.6 or C1S.6) bit is set. If the ERIE, C0IE (or C1IE), and EA SFR bits are configured, an interrupt will be generated. If the ERCS bit is set, the device will generate an interrupt when the CECE bit is set or cleared, if the interrupt is enabled.

BIT TIMING

Bit timing of the CAN transmission can be adjusted per the CAN 2.0B specification. The CAN 0/1 Bus Timing Register Zero (C0BT0 and C1BT0), located in the Control/Status/Mask Register block in MOVX memory, controls the PHASE_SEG1 and PHASE_SEG2 time segments as well as the Baud Rate Pre-scaler (BPR5 - BPR0). The CAN 0/1 Bus Timing Register One (C0BT1 and C1BT1) contains the controls for the sampling rate and the number of clock cycles assigned to the Phase Segment 1 and 2 portions of the Nominal Bit Time. The values of both of the Bus Timing registers are automatically loaded into the CAN Processor following each software change of the SWINT bit from a 1 to a 0 by the microcontroller. The bit timing parameters must be set before starting operation of the CAN Processor. These registers are only modifiable during a software initialization, ($SWINT = 1$), when the CAN Processor is NOT in a bus off mode, and after the removal of a system reset or a CAN reset. To avoid unpredictable behavior of the CAN Processor, the software cannot clear the SWINT bit when TSEG1 and TSEG2 are both cleared to 0.

ABSOLUTE MAXIMUM RATINGS*

Voltage on Any Pin Relative to Ground	-0.3 V to (VCC + 0.5 V)
Voltage on VCC relative to ground	-0.3 V to 6.0 V
Operating Temperature	-40 °C to +85 °C
Storage Temperature	-55 °C to +125 °C
Soldering Temperature	160 °C for 10 seconds

* This is a stress rating only and functional operation of the device at these or any other conditions above those indicated in the operation sections of this specification is not implied. Exposure to absolute maximum rating conditions for extended periods of time may affect reliability.

DC ELECTRICAL CHARACTERISTICS

PARAMETER	SYMBOL	MIN	TYP	MAX	UNITS	NOTES
Supply Voltage	V _{CC}	V _{RST}	5.0	5.5	V	
Power Fail Warning	V _{PFW}	4.25	4.38	4.5	v	
Min. Operating Voltage	V _{RST}	4.0	4.13	4.25	V	
Supply Current Active Mode	I _{CC}		35		mA	1
Supply Current Idle Mode	I _{IDLE}		15		mA	2
Supply Current Stop Mode	I _{STOP}		1		μA	3
Supply Current Stop Mode, Band-gap enabled	I _{SPBG}		200		μA	3
Input Low Level	V _{IL}	-0.5		+0.8	V	
Input High Level	V _{IH}	2.0		V _{CC} +0.5	V	
Input High Level for XTAL1, RST	V _{IH2}	3.5		V _{CC} +0.5	V	
Output Low Voltage for Port 1, 3, 4, 5 @ I _{OL} =1.6 mA	V _{OL1}			0.45	V	10
Output Low Voltage for Port 0, 1, 2, 4, PCE0-3, RD, WR, RSTOL, PSEN, and ALE, @ I _{OL} =3.2 mA	V _{OL2}			0.45	V	4
Output High Voltage for Port 1,3,4,5, @ I _{OH} = -50 μA	V _{OH1}	2.4			v	10
Output High Voltage for Port 1,3,4,5 @ I _{OH} = -1.5 mA	V _{OH2}	2.4			v	5
Output High Voltage for Port 0,1,2,4, PCE0-3, RSTOL, PSEN, RD, WR, and ALE @ I _{OH} = -8 mA	V _{OH3}	2.4			v	4
Input Low Current for Port 1, 3, 4, 5 @0.45V	I _{IL}			-55	μA	7
Logic 1 to 0 Transition Current for Port 1, 3, 4, 5	I _{T1}			-650	μA	8
Input Leakage Current for Port 0 (input mode only)	I _L	-300		+300	μA	9
RST Pulldown Resistance	R _{RST}	50		170	kΩ	

NOTES FOR DC ELECTRICAL CHARACTERISTICS:

1. Active current measured with 40 MHz clock source on XTAL1, $V_{CC}=RST= 5.5$ V, all other pins disconnected.
2. Idle mode current measured with 40 MHz clock source on XTAL1, $V_{CC}= 5.5$ V, $RST=\overline{EA}=V_{SS}$, all other pins disconnected.
3. Stop mode current measured with $XTAL1 = RST = \overline{EA} = V_{SS}$, $V_{CC}= 5.5$ V, all other pins disconnected. This value is not guaranteed. Users who are sensitive to this specification should contact Dallas Semiconductor for more information.
4. When these pins are used to address external memory or as CAN interface signals.
5. This measurement reflects the port during a 0 to 1 transition in I/O mode. During this period a one-shot circuit drives the ports hard for two clock cycles.
6. Port 3 pins 3.6 and 3.7 will have a stronger than normal pullup drive for one oscillator period following the transition of either the \overline{RD} or \overline{WR} from a 0 to 1 transition.
7. This is the current required from an external circuit to hold a logic low level on an I/O pin while the corresponding port latch bit is set to 1. This is only the current required to *hold* the low level; transitions from 1 to 0 on an I/O pin will also have to overcome the transition current.
8. Ports 1(in I/O mode), 3, 4, and 5 source transition current when being pulled down externally. It reaches its maximum at approximately 2V.
9. During the external addressing mode, weak latches maintain the previously driven value from the processor on Port 0 until such time that Port 0 is driven by external memory source; and on Port 1, 2 and 4 for one XTAL1 cycle prior to change in output address from Port 1, 2 and 4.
10. $RST= V_{CC}$. This condition mimics operation of pins in I/O mode.

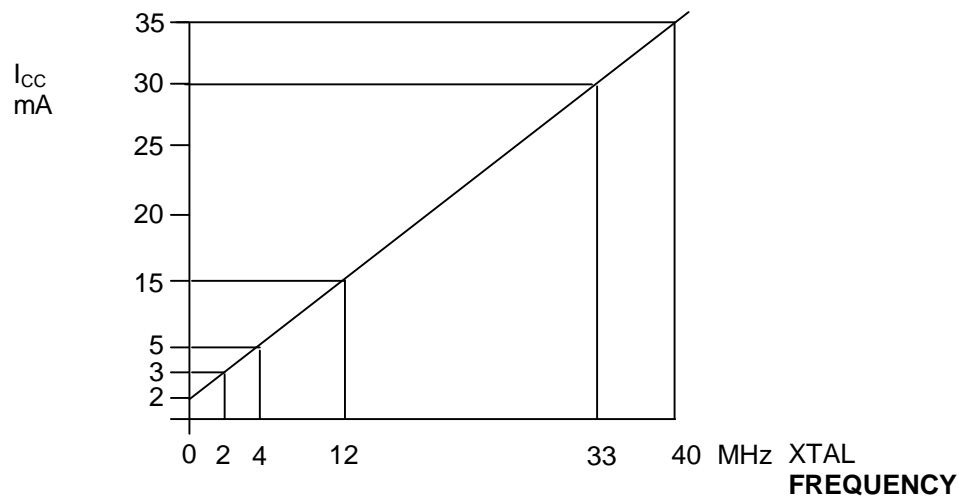
TYPICAL I_{CC} VERSUS FREQUENCY

AC ELECTRICAL CHARACTERISTICS (Multiplexed address/data bus)

PARAMETER	SYMBOL	40 MHz		VARIABLE CLOCK		UNITS
		MIN	MAX	MIN	MAX	
Oscillator Freq. (Ext. Osc) (Ext. Crystal)	$1 / t_{CLCL}$	0 1	40 40	0 1	40 40	MHz
ALE Pulse Width	t_{LHLL}			$0.375 t_{MCS} - 5$		ns
Port 0 Instruction Address or CE0–4 Valid to ALE Low	t_{AVLL}			$0.125 t_{MCS} - 5$		ns
Address Hold after ALE Low	t_{LLAX1}			$0.125 t_{MCS} - 5$		ns
ALE Low to Valid Instruction In	t_{LLIV}				$0.625 t_{MCS} - 20$	ns
ALE Low to \overline{PSEN} Low	t_{LLPL}			$0.125 t_{MCS} - 5$		ns
\overline{PSEN} Pulse Width	t_{PLPH}			$0.5 t_{MCS} - 5$		ns
\overline{PSEN} Low to Valid Instruction In	t_{PLIV}				$0.5 t_{MCS} - 20$	ns
Input Instruction Hold after \overline{PSEN}	t_{PXIX}	0		0		ns
Input Instruction Float after \overline{PSEN}	t_{PXIZ}				$0.25 t_{MCS} - 5$	ns
Port 0 Address to Valid Instruction In	t_{AVIV1}				$0.75 t_{MCS} - 20$	ns
Port 2, 4 Address to Valid Instruction In	t_{AVIV2}				$0.875 t_{MCS} - 25$	ns
\overline{PSEN} Low to Address Float	t_{PLAZ}		0		0	ns

NOTES FOR AC ELECTRICAL CHARACTERISTICS:

- All parameters apply to both commercial and industrial temperature operation unless otherwise noted.
- The value t_{MCS} is a function of the machine cycle clock in terms of the processor's input clock frequency. These relationships are described in the "Stretch Value Timing" table.
- All signals characterized with load capacitance of 80 pF except Port 0, ALE, \overline{PSEN} , \overline{RD} and \overline{WR} with 100 pF.
- Interfacing to memory devices with float times (turn off times) over 25 ns may cause bus contention. This will not damage the parts, but will cause an increase in operating current.
- Specifications assume a 50% duty cycle for the oscillator. Port 2 and ALE timing will change in relation to duty cycle variation.
- Some AC timing characteristic drawings contain references to the CLK signal. This waveform is provided to assist in determining the relative occurrence of events, and cannot be used to determine the timing of signals relative to the external clock.

MULTIPLEXED EXTERNAL PROGRAM MEMORY READ CYCLE

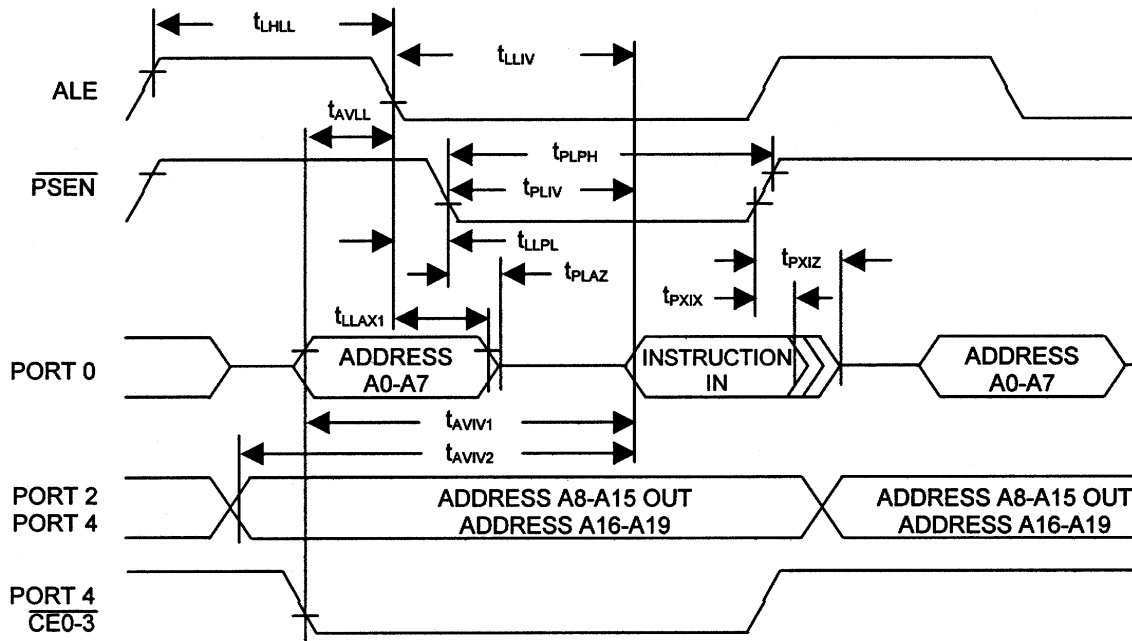

MOVX CHARACTERISTICS (Multiplexed address/data bus)

PARAMETER	SYMBOL	MIN	MAX	UNITS	STRETCH VALUES C_{ST} (MD2:0)
MOVX ALE Pulse Width	t_{LHLL2}	$0.375 t_{MCS} - 5$ $0.5 t_{MCS} - 5$ $1.5 t_{MCS} - 10$		ns	$C_{ST} = 0$ $1 \leq C_{ST} \leq 3$ $4 \leq C_{ST} \leq 7$
Port 0 MOVX Address, CE0-4, PCE0-4 Valid to ALE Low	t_{AVLL2}	$0.125 t_{MCS} - 5$ $0.25 t_{MCS} - 5$ $1.25 t_{MCS} - 10$		ns	$C_{ST} = 0$ $1 \leq C_{ST} \leq 3$ $4 \leq C_{ST} \leq 7$
Address Hold after MOVX Read/Write	t_{LLAX2}	$0.125 t_{MCS} - 5$ $1.125 t_{MCS} - 5$		ns	$0 \leq C_{ST} \leq 3$ $4 \leq C_{ST} \leq 7$
RD Pulse Width	t_{RLRH}	$0.5 t_{MCS} - 5$ $C_{ST} \cdot t_{MCS} - 10$		ns	$C_{ST} = 0$ $1 \leq C_{ST} \leq 7$
WR Pulse Width	t_{WLWH}	$0.5 t_{MCS} - 5$ $C_{ST} \cdot t_{MCS} - 10$		ns	$C_{ST} = 0$ $1 \leq C_{ST} \leq 7$
RD Low to Valid Data In	t_{RLDV}		$0.5 t_{MCS} - 20$ $C_{ST} \cdot t_{MCS} - 20$	ns	$C_{ST} = 0$ $1 \leq C_{ST} \leq 7$
Data Hold after Read	t_{RHDX}	0		ns	
Data Float after Read	t_{RHDZ}		$0.25 t_{MCS} - 5$ $0.5 t_{MCS} - 5$ $1.5 t_{MCS} - 5$	ns	$C_{ST} = 0$ $1 \leq C_{ST} \leq 3$ $4 \leq C_{ST} \leq 7$
ALE Low to Valid Data In	t_{LLDV}		$0.625 t_{MCS} - 20$ $(C_{ST} + 0.25) \cdot t_{MCS} - 40$ $(C_{ST} + 1.25) \cdot t_{MCS} - 40$	ns	$C_{ST} = 0$ $1 \leq C_{ST} \leq 3$ $4 \leq C_{ST} \leq 7$

Port 0 Address, Port 4 CE, Port 5 PCE to Valid Data In	t_{AVDV1}		$0.75 t_{MCS} - 20$ $(C_{ST} + 0.375) \bullet t_{MCS} - 20$ $(C_{ST} + 1.375) \bullet t_{MCS} - 20$	ns	$C_{ST} = 0$ $1 \leq C_{ST} \leq 3$ $4 \leq C_{ST} \leq 7$
Port 2, 4 Address to Valid Data In	t_{AVDV2}		$0.875 t_{MCS} - 20$ $(C_{ST} + 0.5) \bullet t_{MCS} - 20$ $(C_{ST} + 1.5) \bullet t_{MCS} - 20$	ns	$C_{ST} = 0$ $1 \leq C_{ST} \leq 3$ $4 \leq C_{ST} \leq 7$
ALE Low to \overline{RD} or \overline{WR} Low	t_{LLWL}	$0.125 t_{MCS} - 5$ $0.25 t_{MCS} - 5$ $1.25 t_{MCS} - 10$	$0.125 t_{MCS} + 5$ $0.25 t_{MCS} + 5$ $1.25 t_{MCS} + 10$	ns	$C_{ST} = 0$ $1 \leq C_{ST} \leq 3$ $4 \leq C_{ST} \leq 7$
Port 0 Address, Port 4 CE, Port 5 PCE to \overline{RD} or \overline{WR} Low	t_{AVWL1}	$0.25 t_{MCS} - 5$ $0.5 t_{MCS} - 5$ $2.5 t_{MCS} - 10$		ns	$C_{ST} = 0$ $1 \leq C_{ST} \leq 3$ $4 \leq C_{ST} \leq 7$
Port 2, 4 Address to or \overline{WR} Low	t_{AVWL2}	$0.375 t_{MCS} - 5$ $0.625 t_{MCS} - 5$ $2.625 t_{MCS} - 10$		ns	$C_{ST} = 0$ $1 \leq C_{ST} \leq 3$ $4 \leq C_{ST} \leq 7$
Data Valid to \overline{WR} Transition	t_{QVWX}	-5		ns	
Data hold after \overline{WR} high	t_{WHQX}	$0.25 t_{MCS} - 5$ $0.5 t_{MCS} - 5$ $1.5 t_{MCS} - 10$		ns	$C_{ST} = 0$ $1 \leq C_{ST} \leq 3$ $4 \leq C_{ST} \leq 7$
\overline{RD} Low to Address Float	t_{RLAZ}		$-(0.125 t_{MCS} - 5)$	ns	$0 \leq C_{ST} \leq 7$
\overline{RD} or \overline{WR} High to ALE, Port 4 CE or Port 5 PCE High	t_{WHLH}	0 $0.25 t_{MCS} - 5$ $1.25 t_{MCS} - 10$	10 $0.25 t_{MCS} + 5$ $1.25 t_{MCS} + 10$	ns	$C_{ST} = 0$ $1 \leq C_{ST} \leq 3$ $4 \leq C_{ST} \leq 7$

NOTES FOR MOVX CHARACTERISTICS:

- All parameters apply to both commercial and industrial temperature operation unless otherwise noted.
- C_{ST} is the stretch cycle value as determined by the MD2, MD1, & MD0 bits of the CKCON register.
 t_{MCS} is a time period determined by the stretch cycle value, shown in the following table.

t_{MCS} TIME PERIODS

System Clock Selection			t_{MCS}
$4X/2X$	CD1	CD0	
1	0	0	$0.5 t_{CLCL}$
0	0	0	$1 t_{CLCL}$
X	1	0	$4 t_{CLCL}$
X	1	1	$1024 t_{CLCL}$

Multiplexed Address/Data PCE0-3 MOVX Read Operation (9 cycle shown for reference)

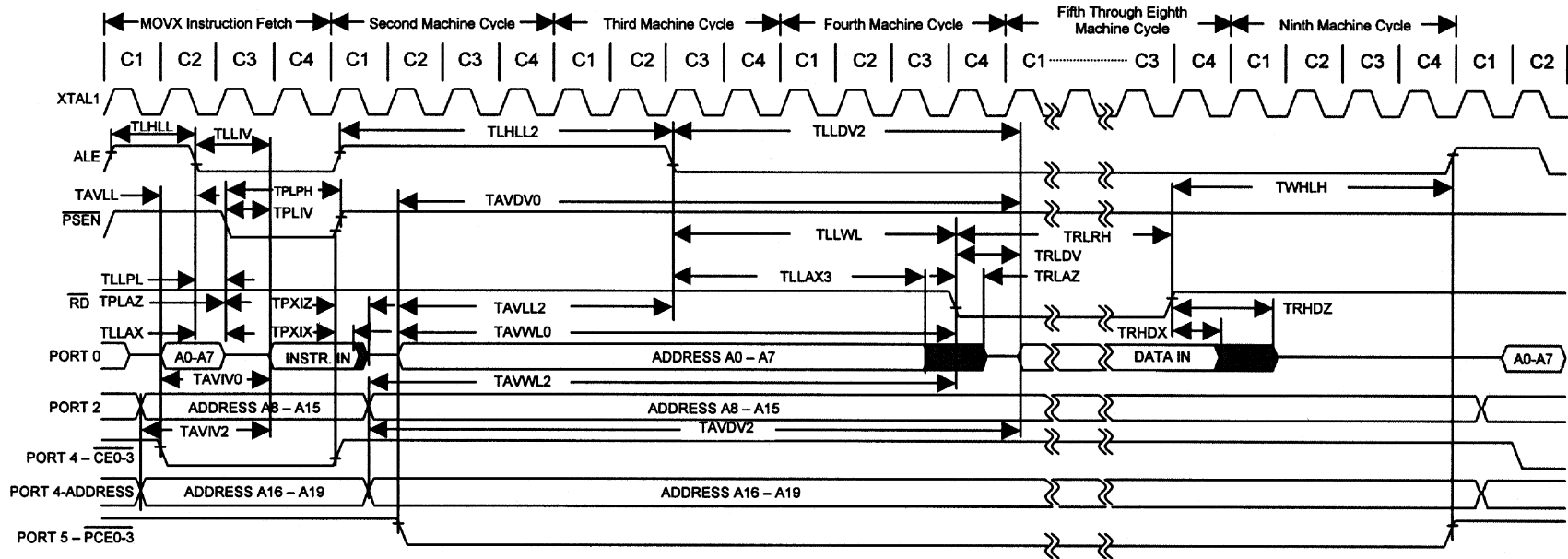

Multiplexed Address/Data PCE0-3 MOVX Write Operation (9 cycle shown for reference)

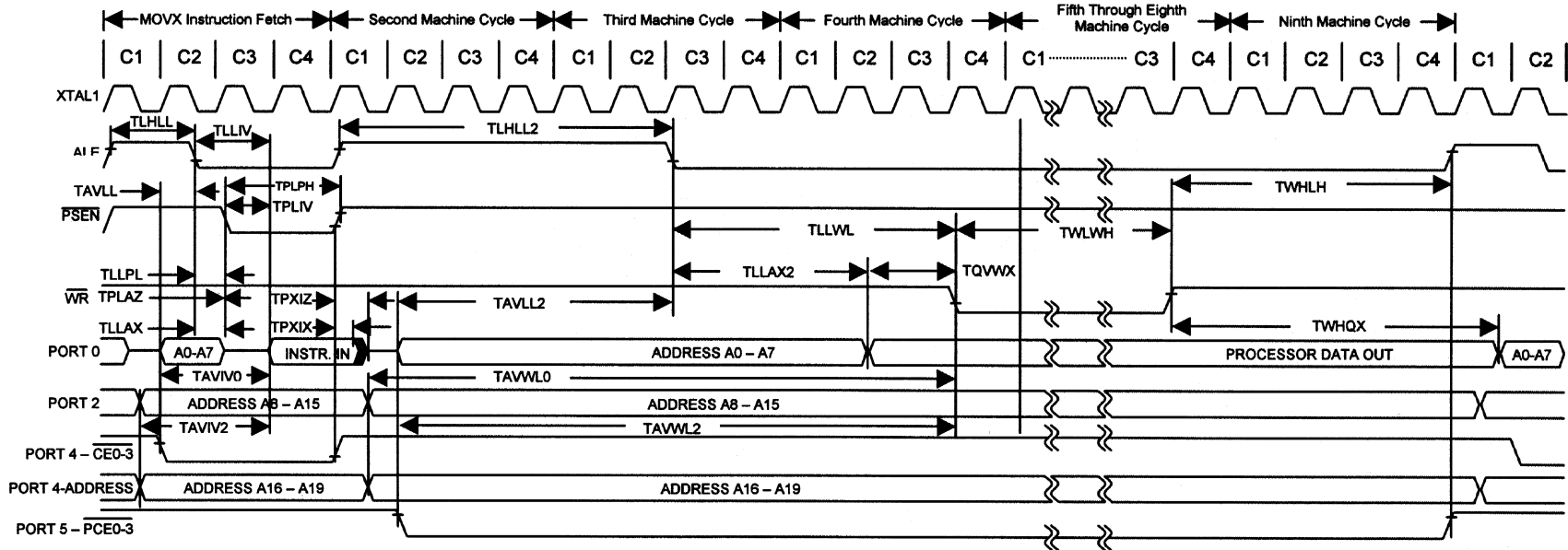

MULTIPLEXED 2 CYCLE DATA MEMORY PCE0-3 READ OR WRITE

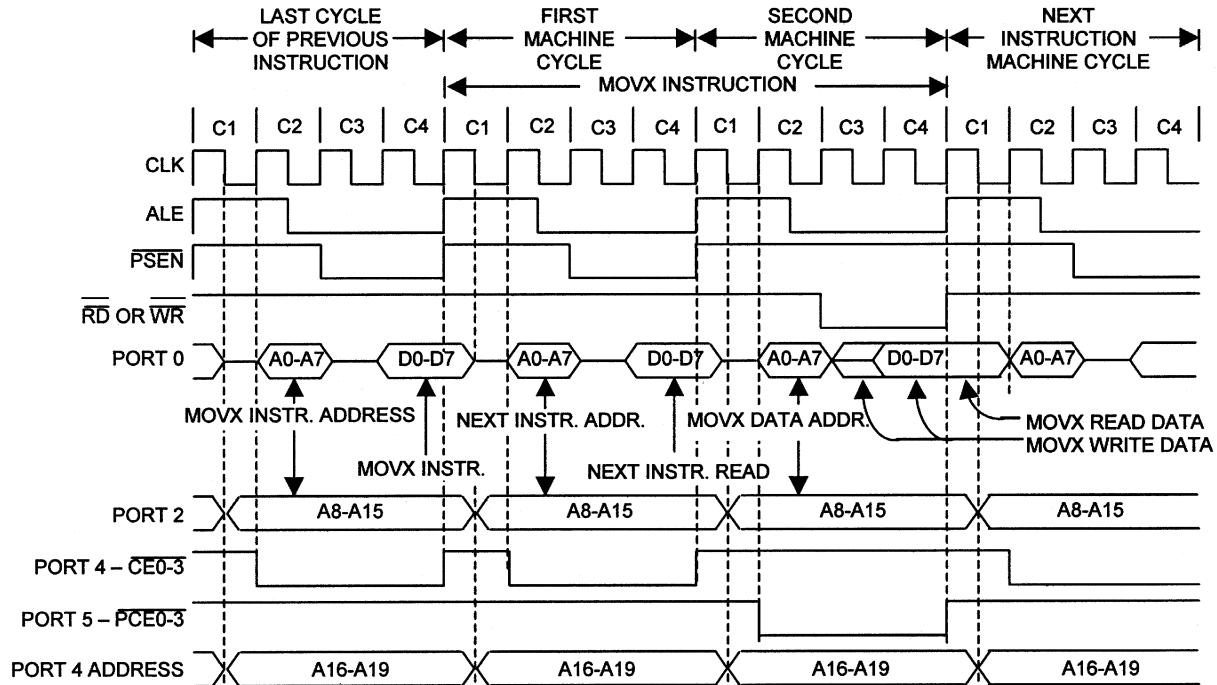

MULTIPLEXED 2 CYCLE DATA MEMORY CE0-3 READ

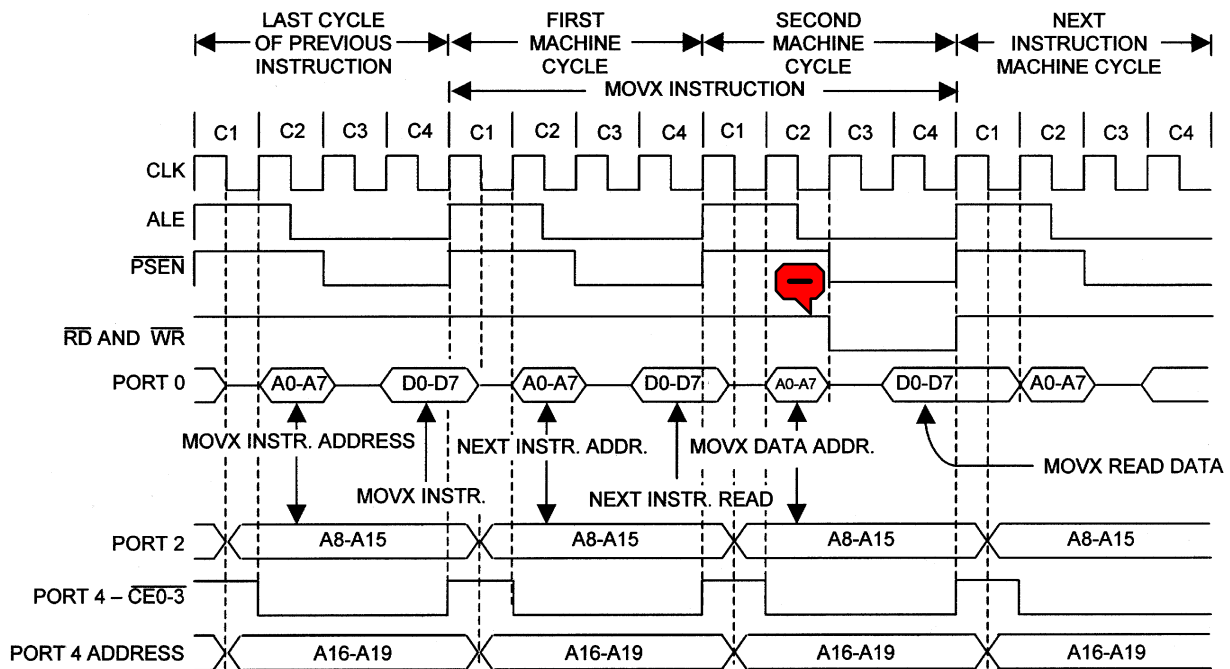

MULTIPLEXED 2 CYCLE DATA MEMORY CE0-3 WRITE

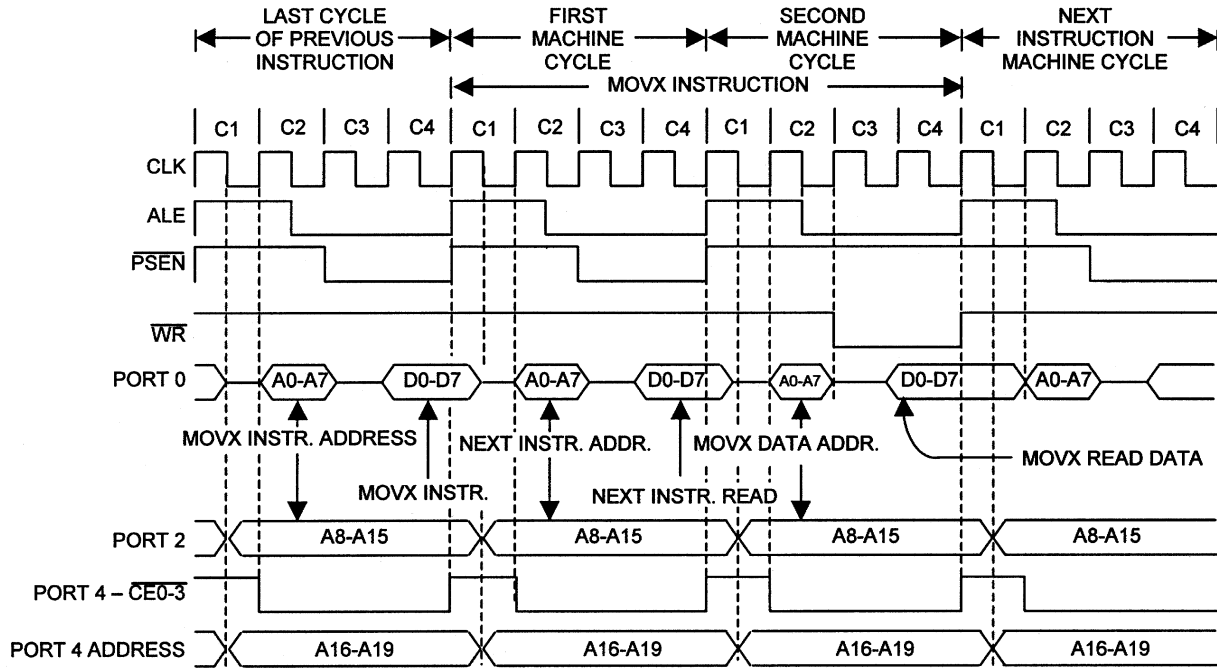

MULTIPLEXED 3 CYCLE DATA MEMORY PCE0-3 READ OR WRITE

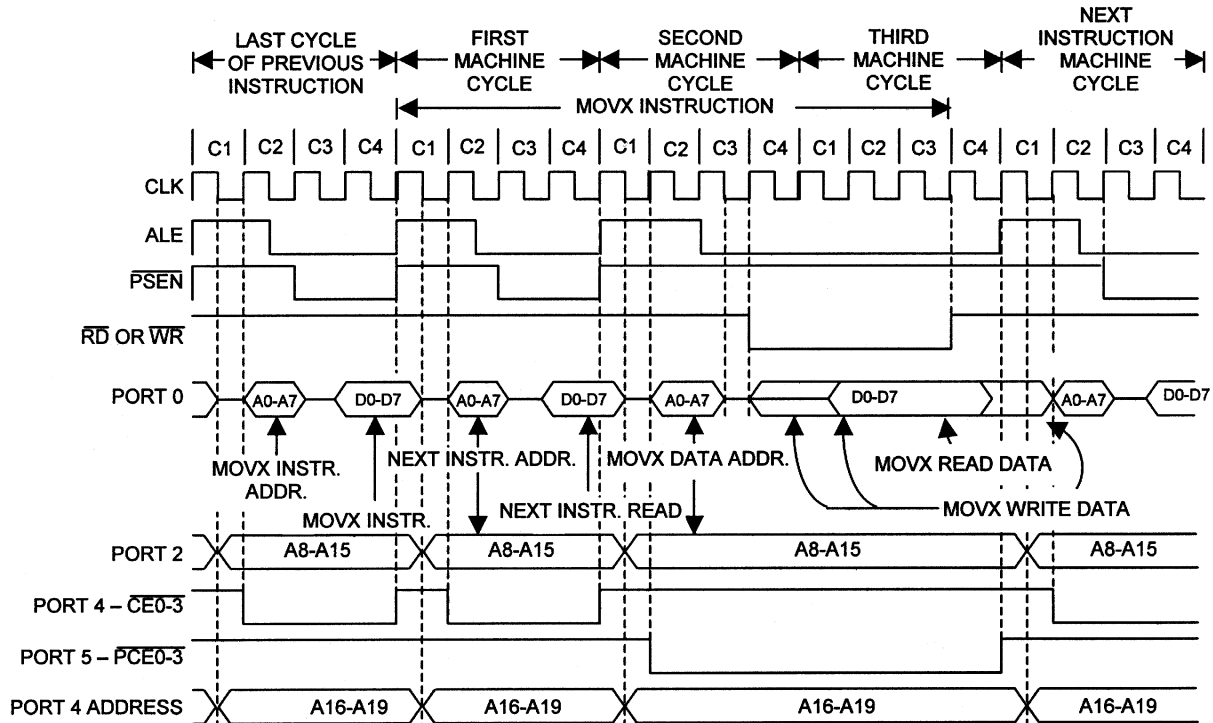

MULTIPLEXED 3 CYCLE DATA MEMORY CE0-3 READ

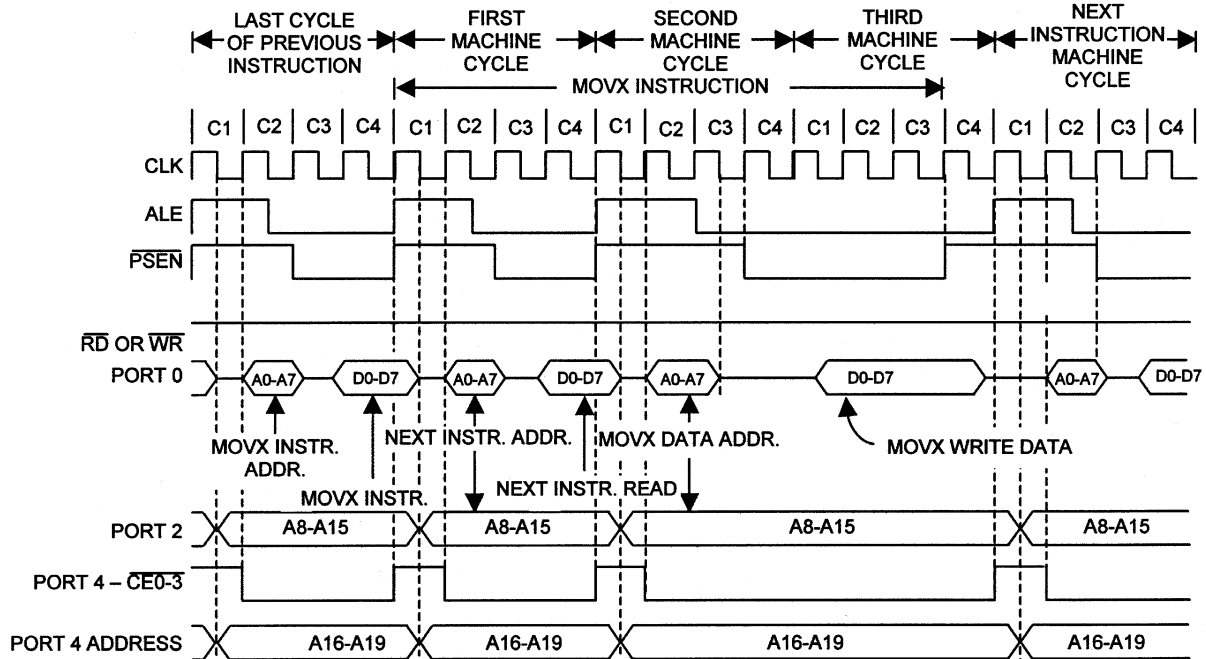

MULTIPLEXED 3 CYCLE DATA MEMORY CE0-3 WRITE

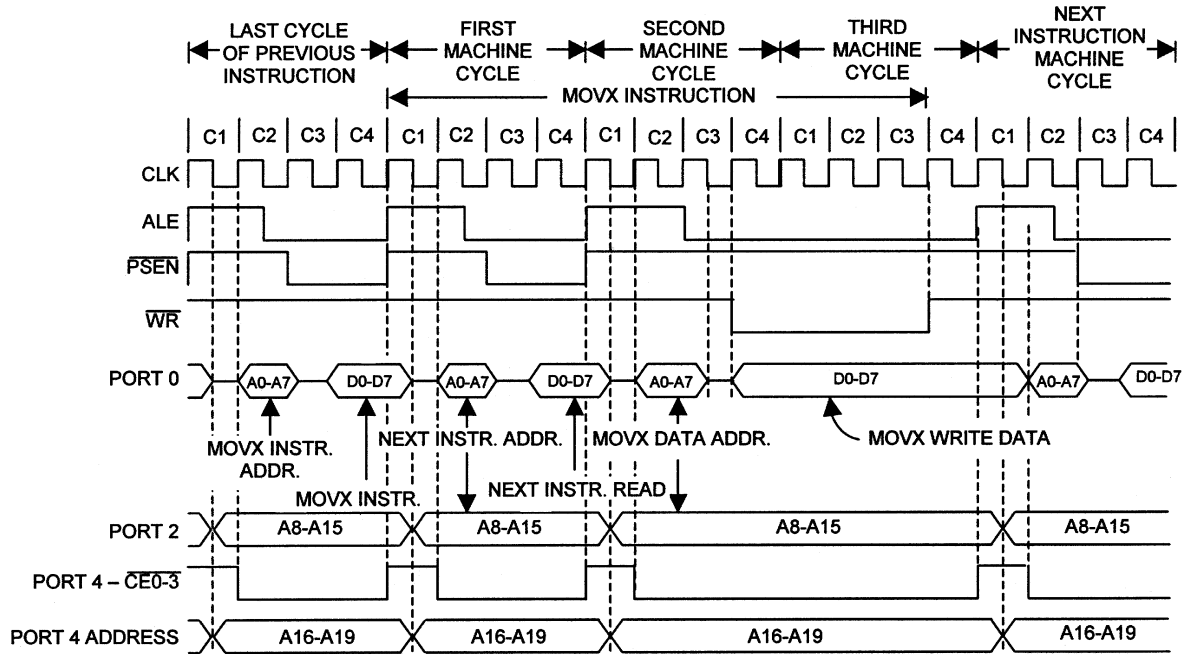

MULTIPLEXED 9 CYCLE DATA MEMORY PCE0-3 READ OR WRITE

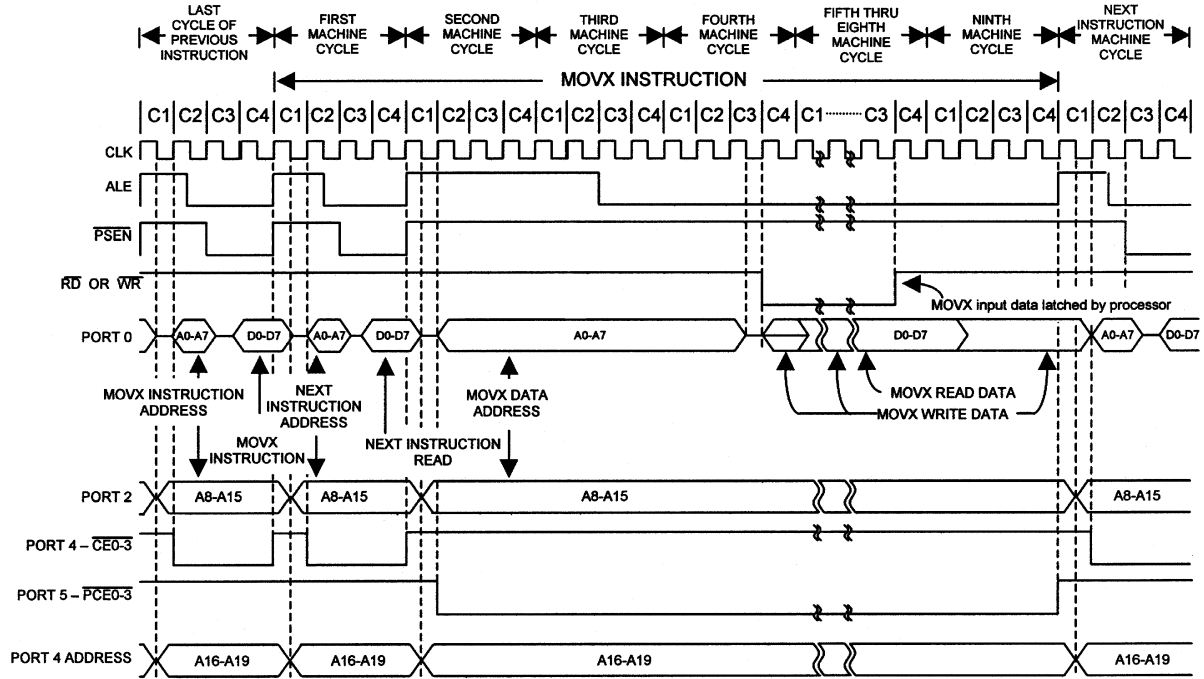

MULTIPLEXED 9 CYCLE DATA MEMORY CE0-3 READ

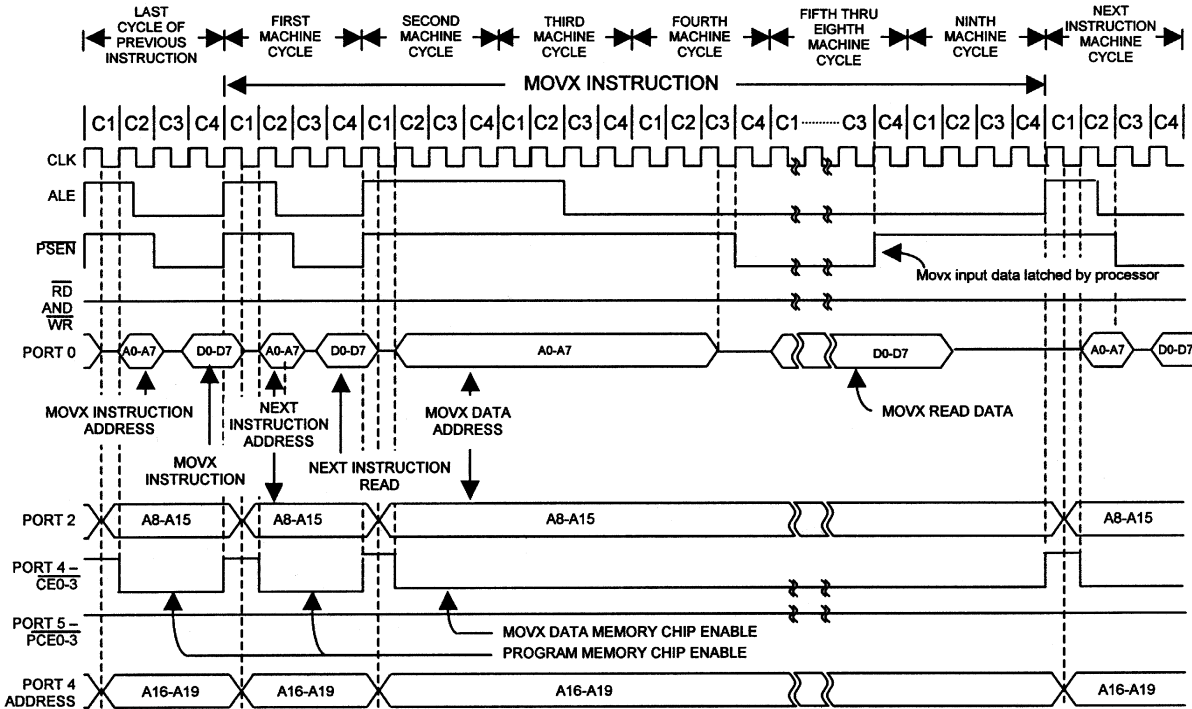

MULTIPLEXED 9 CYCLE DATA MEMORY CE0-3 WRITE

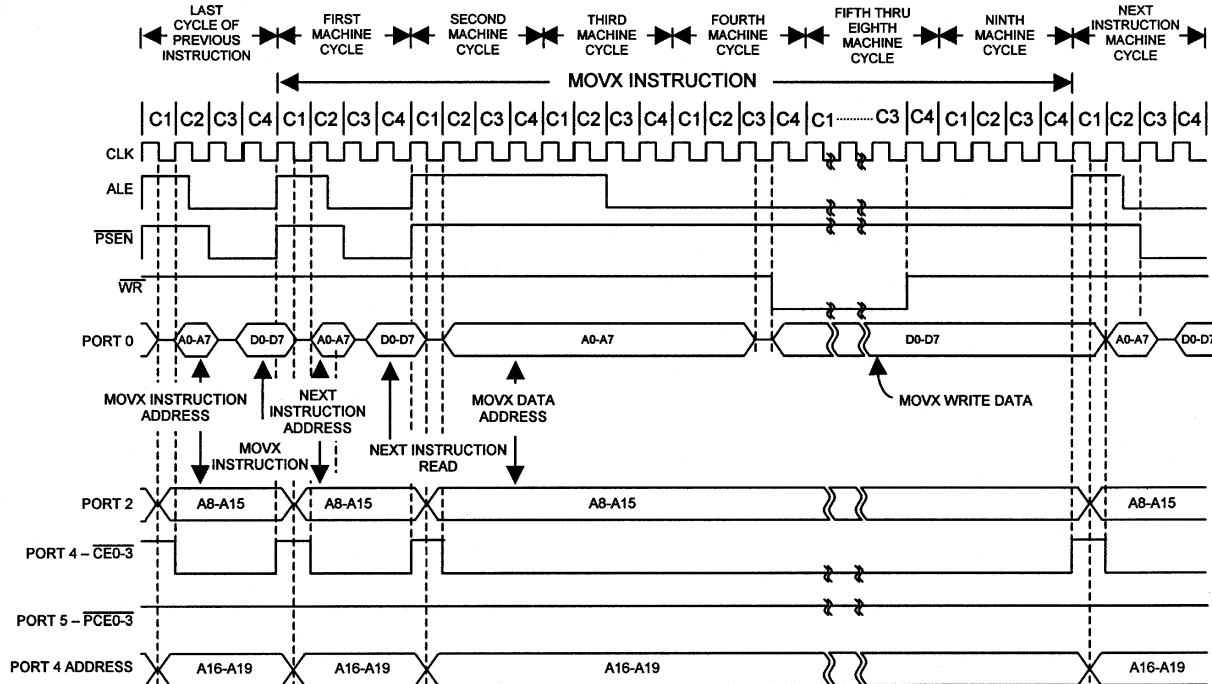

ELECTRICAL CHARACTERISTICS (Non-multiplexed address/data bus)

PARAMETER	SYMBOL	40 MHz		VARIABLE CLOCK		UNITS
		MIN	MAX	MIN	MAX	
Oscillator Freq. (Ext. Osc)	$1 / t_{CLCL}$	0	40	0	40	MHz
(Ext. Crystal)		1	40	1	40	
PSEN Pulse Width	t_{PLPH}			$0.5 t_{MCS} - 5$		ns
PSEN Low to Valid Instruction In	t_{PLIV}			$0.5 t_{MCS} - 20$		ns
Input Instruction Hold after PSEN	t_{PXIX}	0		0		ns
Input Instruction Float after PSEN	t_{PXIZ}					See MOVX characteristics
Port 1 Address, Port 4 CE to Valid Instruction In	t_{AVIV1}				$0.75 t_{MCS} - 20$	ns
Port 2, 4 Address to Valid Instruction In	t_{AVIV2}				$0.875 t_{MCS} - 25$	ns

NOTES FOR AC ELECTRICAL CHARACTERISTICS:

1. All parameters apply to both commercial and industrial temperature operation unless otherwise noted.
2. The value t_{MCS} is a function of the machine cycle clock in terms of the processor's input clock frequency. These relationships are described in the "Stretch Value Timing" table.
3. All signals characterized with load capacitance of 80 pF except Port 0, ALE, PSEN, RD and WR with 100 pF.
4. Interfacing to memory devices with float times (turn off times) over 25 ns may cause bus contention. This will not damage the parts, but will cause an increase in operating current.
5. Specifications assume a 50% duty cycle for the oscillator. Port 2 timing will change in relation to duty cycle variation.

NON-MULTIPLEXED EXTERNAL PROGRAM MEMORY READ CYCLE

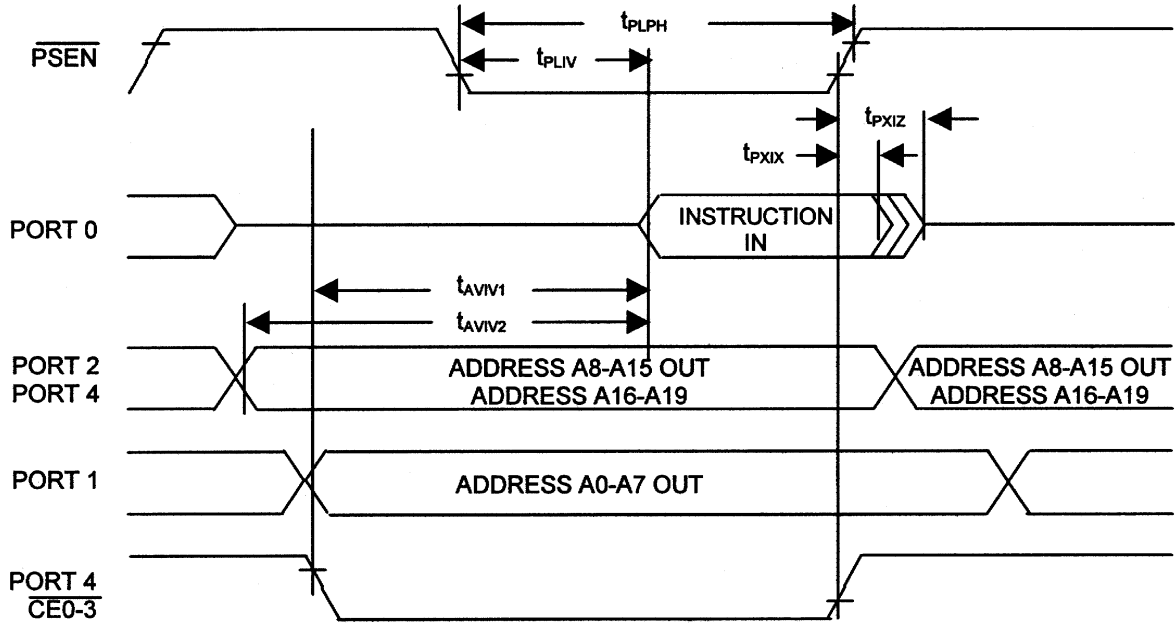

MOVX CHARACTERISTICS (Non-multiplexed address/data bus)

PARAMETER	SYMBOL	MIN	MAX	UNITS	STRETCH VALUES C_{ST} (MD2:0)
Input Instruction Float after \overline{PSEN}	t_{PXIZ}	0.5 $t_{MCS} - 5$ 0.75 $t_{MCS} - 5$ 2.75 $t_{MCS} - 10$		ns	$C_{ST} = 0$ $1 \leq C_{ST} \leq 3$ $4 \leq C_{ST} \leq 7$
\overline{PSEN} High to Data Address, Port 4 CE, Port 5 PCE Valid	t_{PHAV}	0.25 $t_{MCS} - 5$		ns	
\overline{RD} Pulse Width	t_{RLRH}	0.5 $t_{MCS} - 5$ $C_{ST} \bullet t_{MCS} - 10$		ns	$C_{ST} = 0$ $1 \leq C_{ST} \leq 7$
\overline{WR} Pulse Width	t_{WLWH}	0.5 $t_{MCS} - 5$ $C_{ST} \bullet t_{MCS} - 10$		ns	$C_{ST} = 0$ $1 \leq C_{ST} \leq 7$
\overline{RD} Low to Valid Data In	t_{RLDV}		0.5 $t_{MCS} - 20$ $C_{ST} \bullet t_{MCS} - 20$	ns	$C_{ST} = 0$ $1 \leq C_{ST} \leq 7$
Data Hold after Read	t_{RHDX}	0		ns	
Data Float after Read	t_{RHDZ}		0.5 $t_{MCS} - 5$ 0.75 $t_{MCS} - 5$ 1.75 $t_{MCS} - 5$	ns	$C_{ST} = 0$ $1 \leq C_{ST} \leq 3$ $4 \leq C_{ST} \leq 7$
\overline{PSEN} High to \overline{WR} Low	t_{PHWL}		0.5 $t_{MCS} - 5$ 0.75 $t_{MCS} - 5$ 2.75 $t_{MCS} - 5$	ns	$C_{ST} = 0$ $1 \leq C_{ST} \leq 3$ $4 \leq C_{ST} \leq 7$
Data Float after Read	t_{PHRL}		0.5 $t_{MCS} - 5$ 0.75 $t_{MCS} - 5$ 2.75 $t_{MCS} - 5$	ns	$C_{ST} = 0$ $1 \leq C_{ST} \leq 3$ $4 \leq C_{ST} \leq 7$
Port 1 Address, Port 4 CE, Port 5 PCE to Valid Data In	t_{AVDV1}		0.75 $t_{MCS} - 20$ ($C_{ST} + 0.5$) $\bullet t_{MCS} - 20$ ($C_{ST} + 2.5$) $\bullet t_{MCS} - 20$	ns	$C_{ST} = 0$ $1 \leq C_{ST} \leq 3$ $4 \leq C_{ST} \leq 7$
Port 2, 4 Address to Valid Data In	t_{AVDV2}		0.875 $t_{MCS} - 20$ ($C_{ST} + 0.625$) $\bullet t_{MCS} - 20$ ($C_{ST} + 2.625$) $\bullet t_{MCS} - 20$	ns	$C_{ST} = 0$ $1 \leq C_{ST} \leq 3$ $4 \leq C_{ST} \leq 7$
Port 0 Address, Port 4 CE, Port 5 PCE to \overline{RD} or \overline{WR} Low	t_{AVWL1}	0.25 $t_{MCS} - 5$ 0.5 $t_{MCS} - 5$ 2.5 $t_{MCS} - 10$		ns	$C_{ST} = 0$ $1 \leq C_{ST} \leq 3$ $4 \leq C_{ST} \leq 7$
Port 2, 4 Address to \overline{RD} or \overline{WR} Low	t_{AVWL2}	0.375 $t_{MCS} - 5$ 0.625 $t_{MCS} - 5$ 2.625 $t_{MCS} - 10$		ns	$C_{ST} = 0$ $1 \leq C_{ST} \leq 3$ $4 \leq C_{ST} \leq 7$
Data Valid to \overline{WR} Transition	t_{QVWX}	-5		ns	
Data hold after \overline{WR} high	t_{WHQX}	0.25 $t_{MCS} - 5$ 0.5 $t_{MCS} - 5$ 1.5 $t_{MCS} - 10$		ns	$C_{ST} = 0$ $1 \leq C_{ST} \leq 3$ $4 \leq C_{ST} \leq 7$
\overline{RD} or \overline{WR} High to ALE, Port 4 CE or Port 5 PCE High	t_{WHCEH}	0 0.25 $t_{MCS} - 5$ 1.25 $t_{MCS} - 5$	10 0.25 $t_{MCS} + 5$ 1.25 $t_{MCS} + 5$	ns	$C_{ST} = 0$ $1 \leq C_{ST} \leq 3$ $4 \leq C_{ST} \leq 7$

Non-Multiplexed Address/Data PCE0-3 MOVX Read Operation (9 cycle shown for reference)

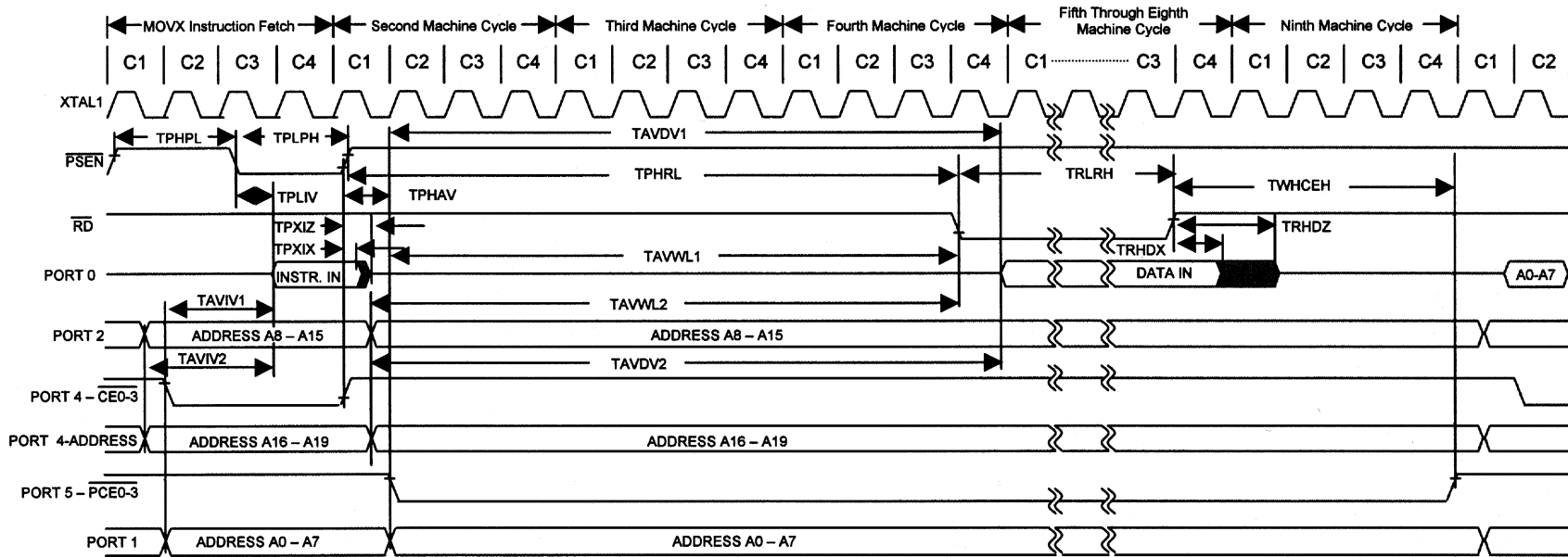

Non-Multiplexed Address/Data PCE0-3 MOVX Write Operation (9 cycle shown for reference)

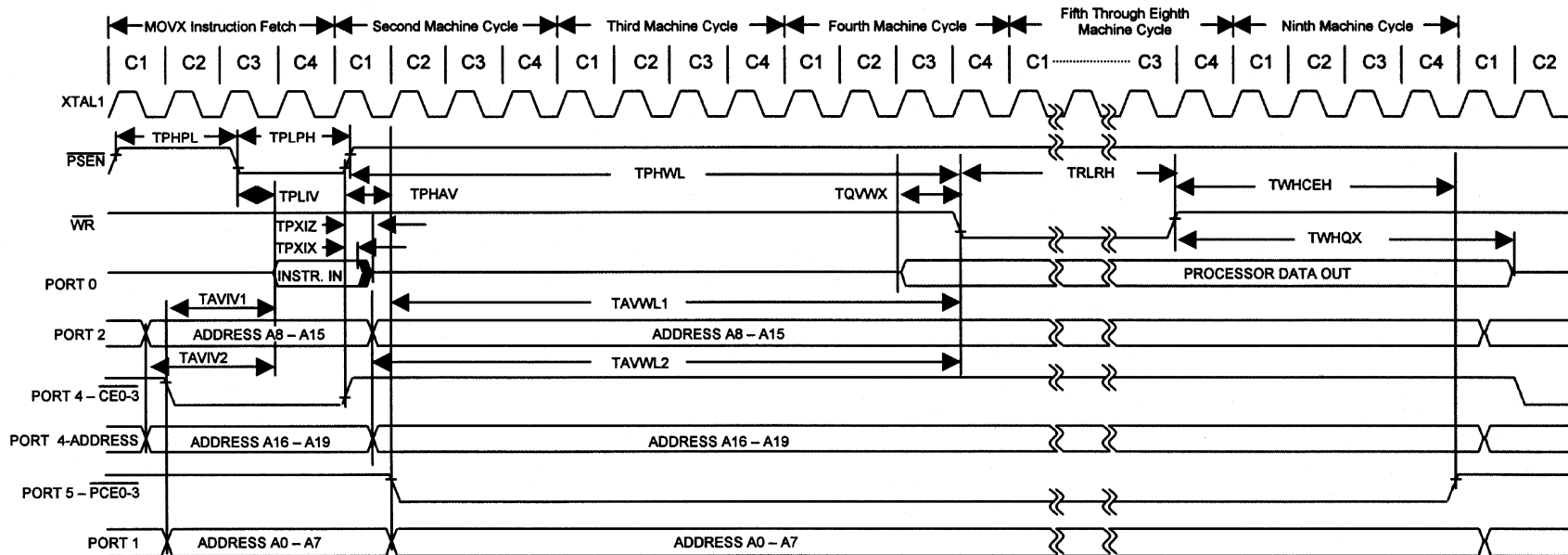

NON-MULTIPLEXED 2 CYCLE DATA MEMORY PCE0-3 READ OR WRITE

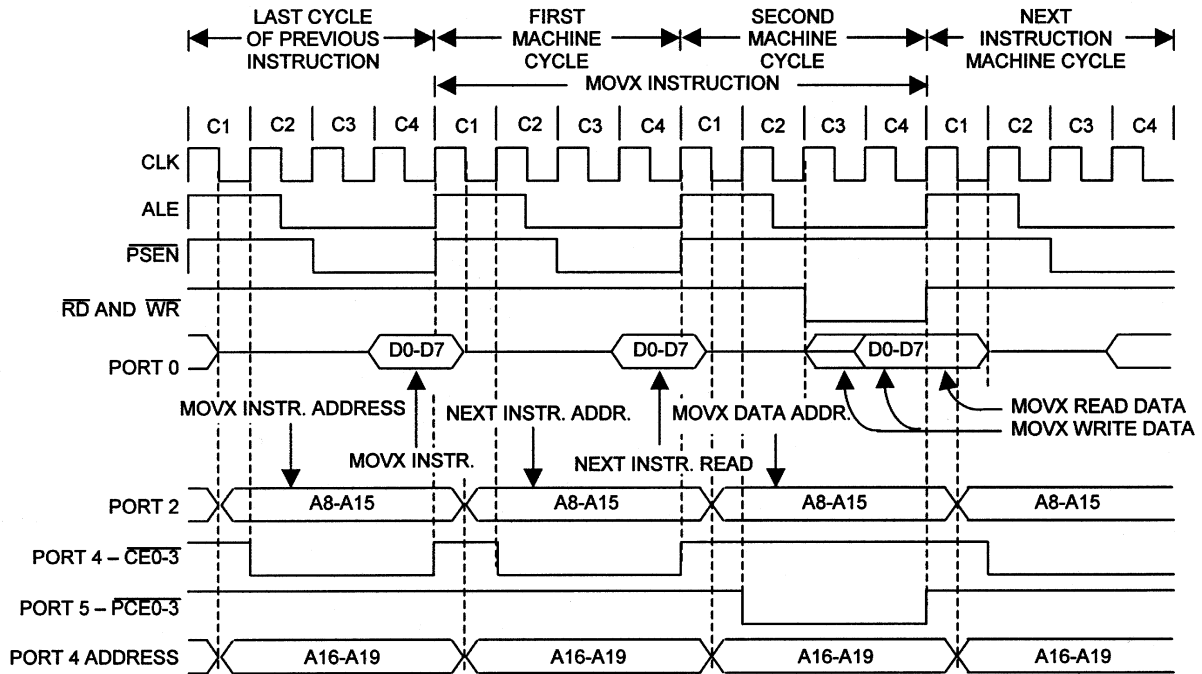

NON-MULTIPLEXED 2 CYCLE DATA MEMORY CE0-3 READ

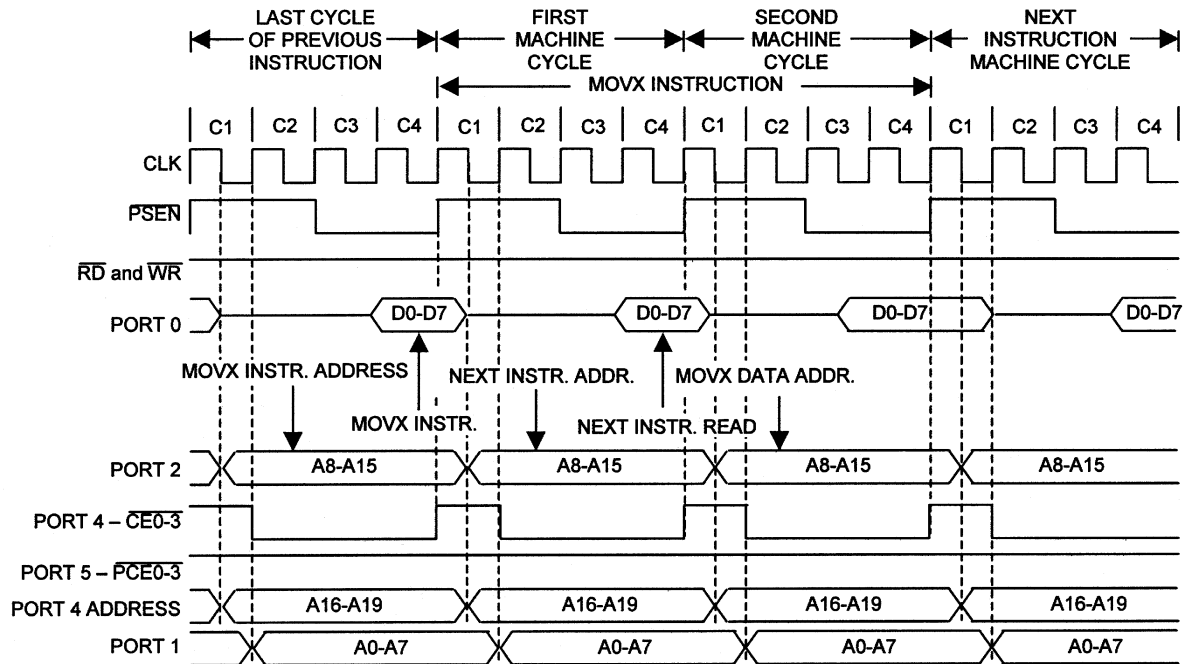

NON-MULTIPLEXED 2 CYCLE DATA MEMORY CE0-3 WRITE

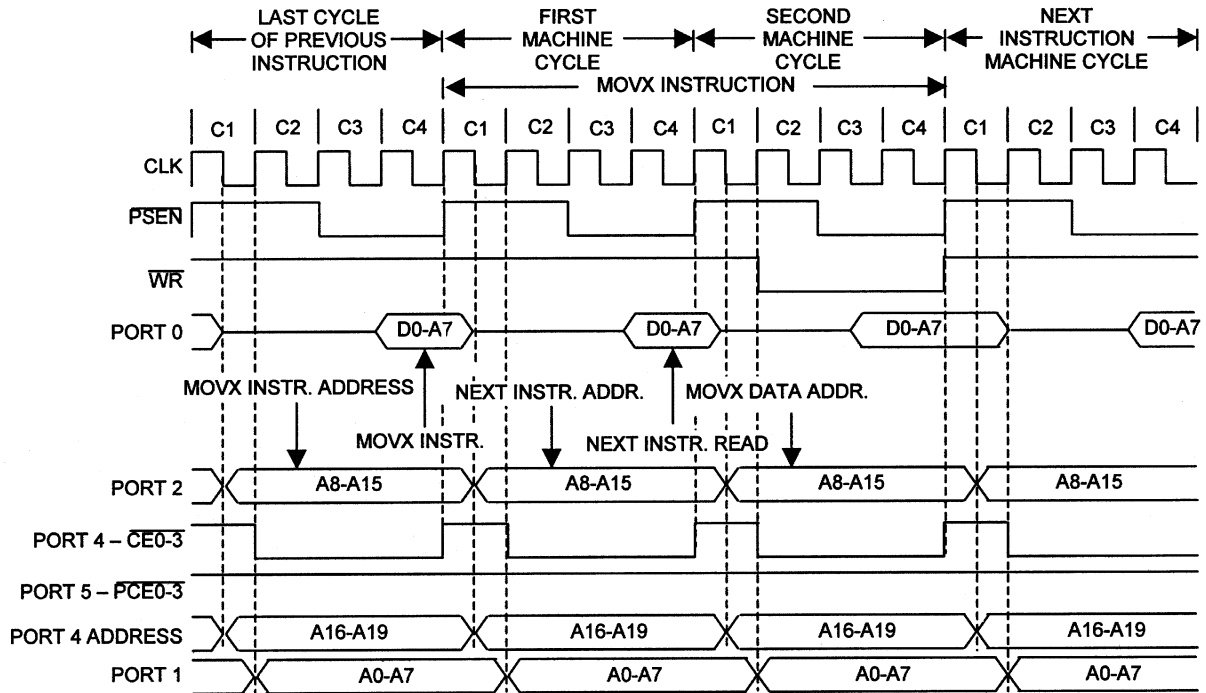

NON-MULTIPLEXED 3 CYCLE DATA MEMORY PCE0-3 READ OR WRITE

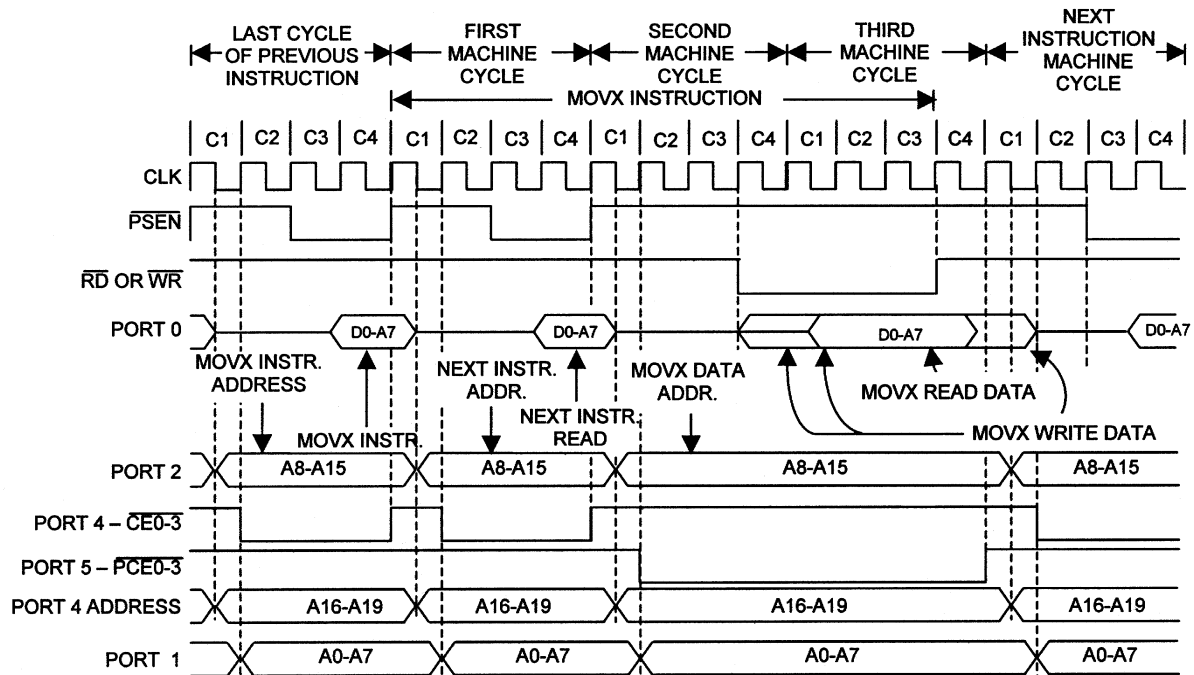

NON-MULTIPLEXED 3 CYCLE DATA MEMORY CE0-3 READ

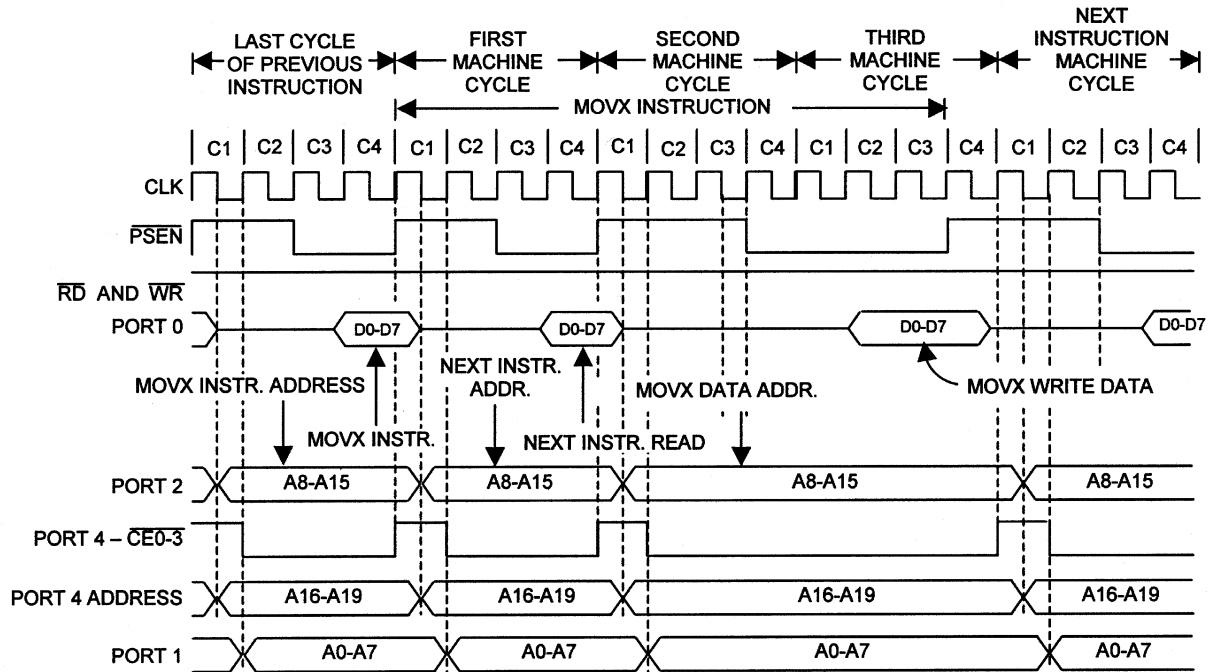

NON-MULTIPLEXED 3 CYCLE DATA MEMORY CE0-3 WRITE

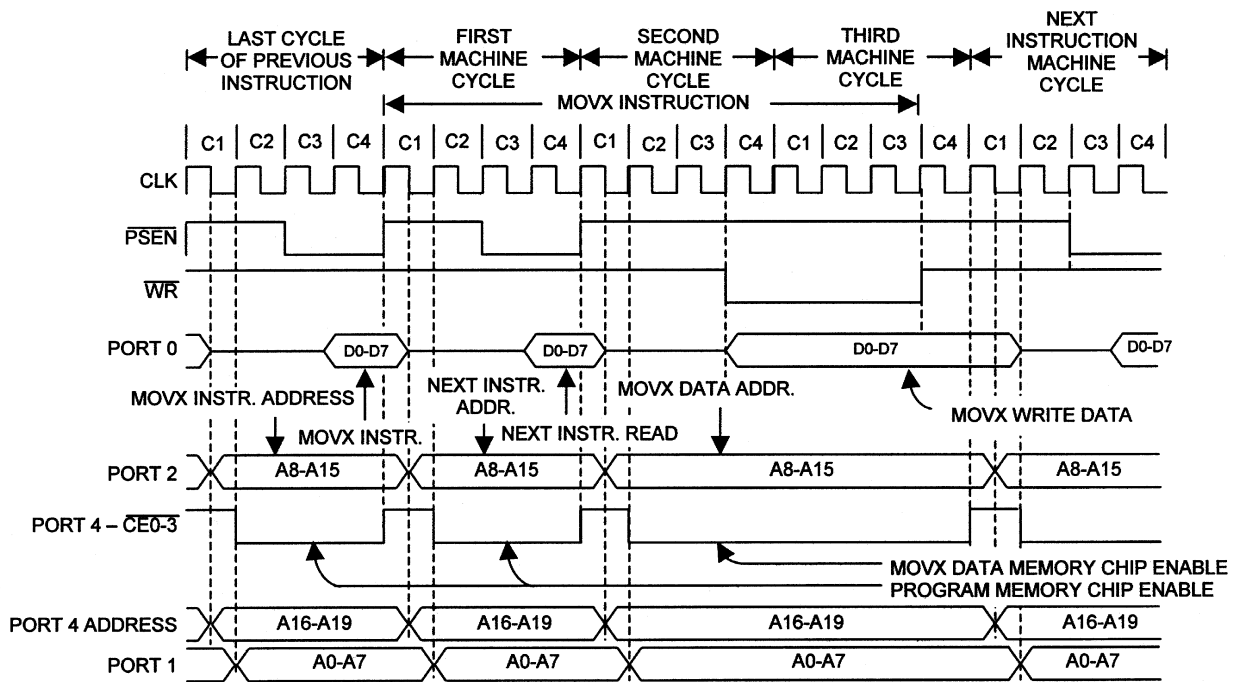

NON-MULTIPLEXED 9 CYCLE DATA MEMORY PCE0-3 READ OR WRITE

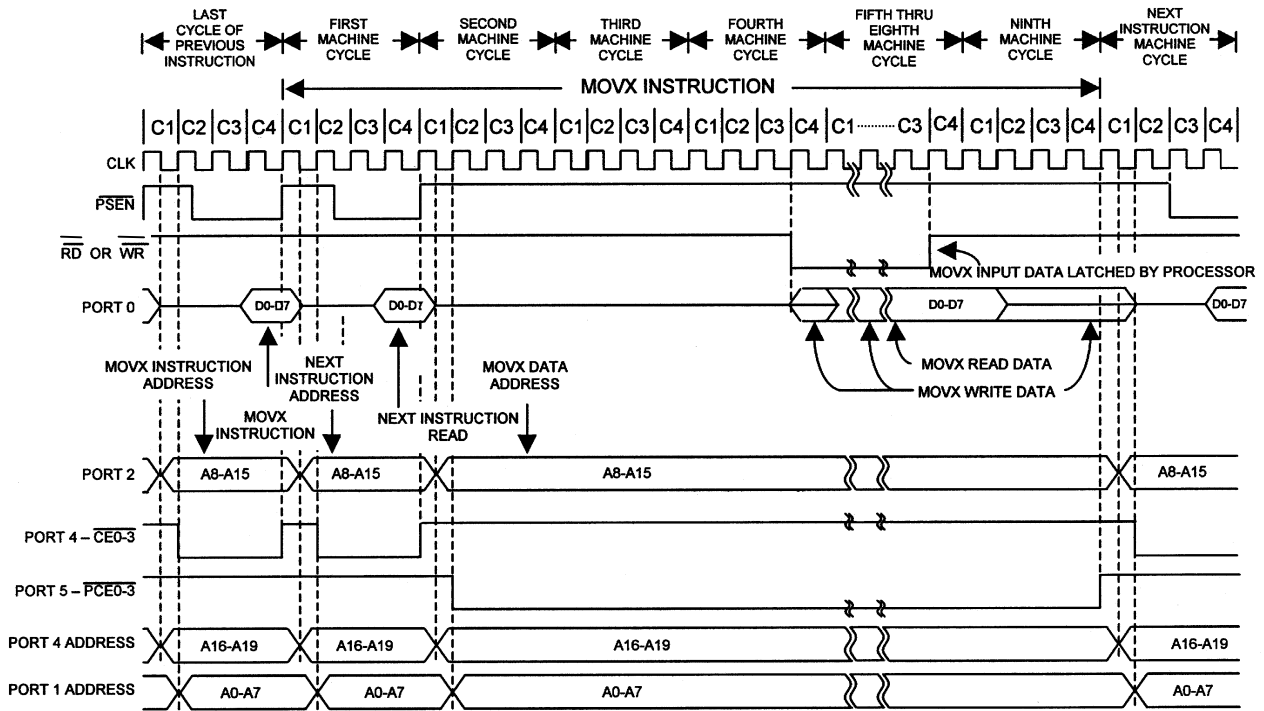

NON-MULTIPLEXED 9 CYCLE DATA MEMORY CE0-3 READ

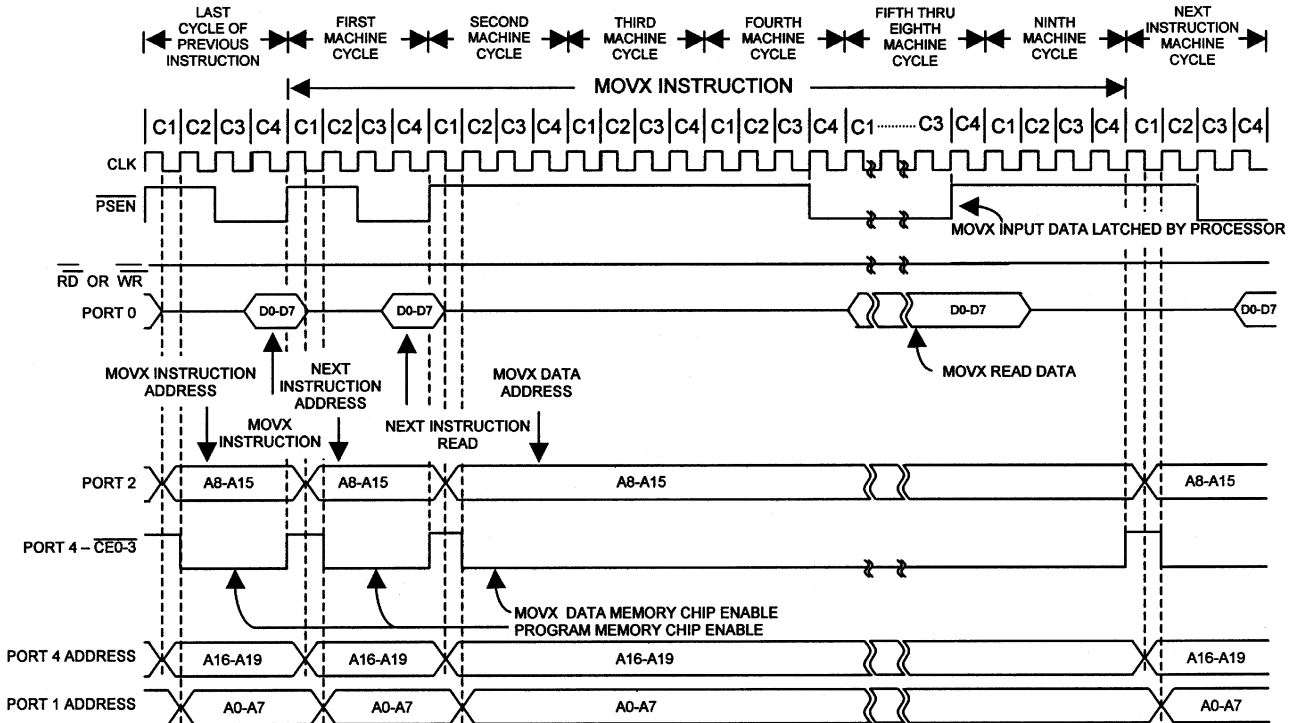

NON-MULTIPLEXED 9 CYCLE DATA MEMORY CE0-3 WRITE

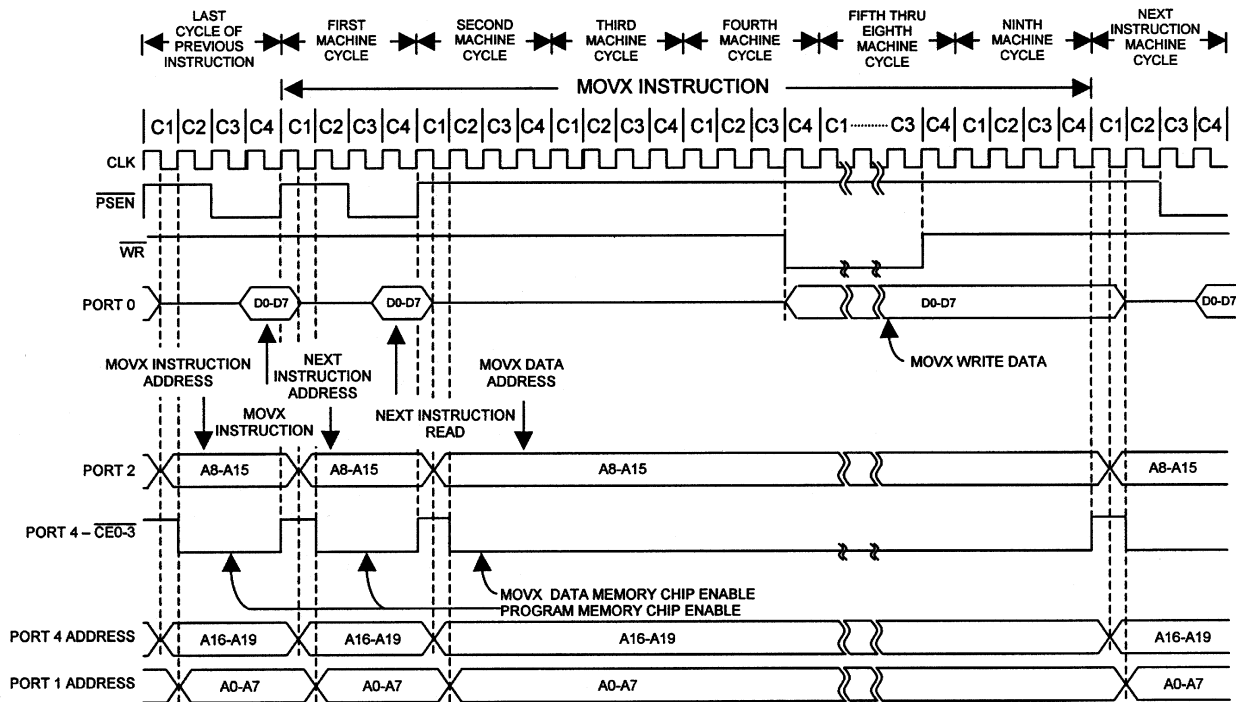

t_{MCS} TIME PERIODS

System Clock Selection				t _{MCS}
4X/2X	CD1	CD0		
1	0	0		0.5 t _{CLCL}
0	0	0		1 t _{CLCL}
X	1	0		4 t _{CLCL}
X	1	1		1024 t _{CLCL}

EXTERNAL CLOCK CHARACTERISTICS

PARAMETER	SYMBOL	MIN	MAX	UNITS
Clock high time	t _{CHCX}	8		ns
Clock low time	t _{CLCX}	8		ns
Clock rise time	t _{CLCH}		4	ns
Clock fall time	t _{CHCL}		4	ns

EXTERNAL CLOCK DRIVE

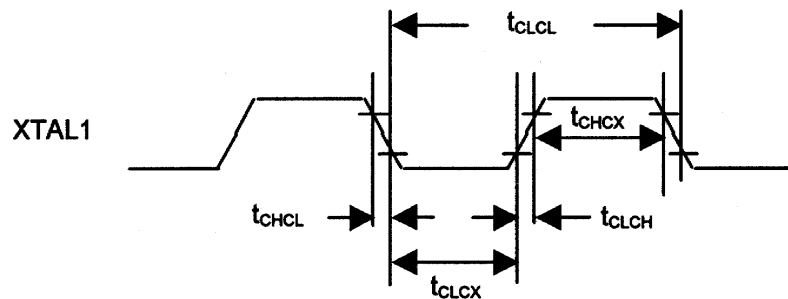

SERIAL PORT MODE 0 TIMING CHARACTERISTICS

PARAMETER	SYMBOL	TYPICAL	UNITS
Serial port clock cycle time SM2=0:2 clocks per cycle SM2=1:4 clocks per cycle	t_{XLXL}	12 t_{CLCL} 4 t_{CLCL}	ns ns
Output data setup to clock rising SM2=0:12 clocks per cycle SM2=1:4 clocks per cycle	t_{QVXH}	10 t_{CLCL} 3 t_{CLCL}	ns ns
Output data hold from clock rising M2=0:12 clocks per cycle SM2=1:4 clocks per cycle	t_{XHQX}	2 t_{CLCL} t_{CLCL}	ns ns
Input data hold after clock rising SM2=0:12 clocks per cycle SM2=1:4 clocks per cycle	t_{XHDX}	t_{CLCL} t_{CLCL}	ns ns
Clock rising edge to input data valid SM2=0:12 clocks per cycle SM2=1:4 clocks per cycle	t_{XHDV}	11 t_{CLCL} 3 t_{CLCL}	ns ns

SERIAL PORT 0 (SYNCHRONOUS MODE)

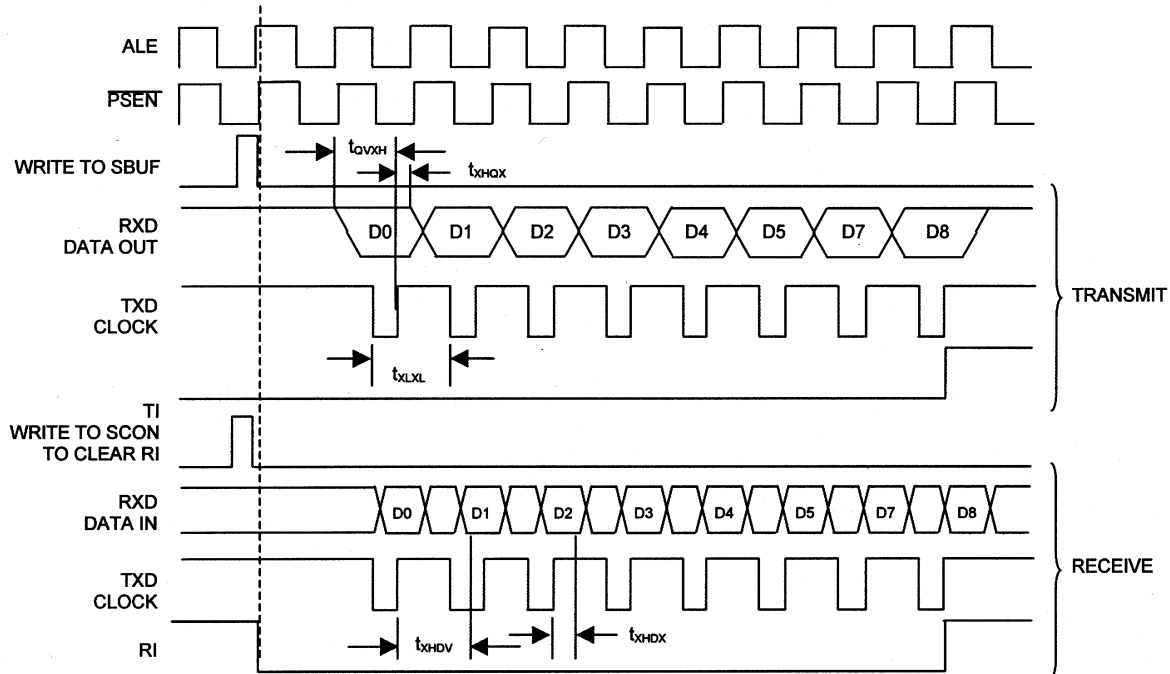

HIGH-SPEED OPERATION, TXD CLK = XTAL/4 (SM2 = 1)

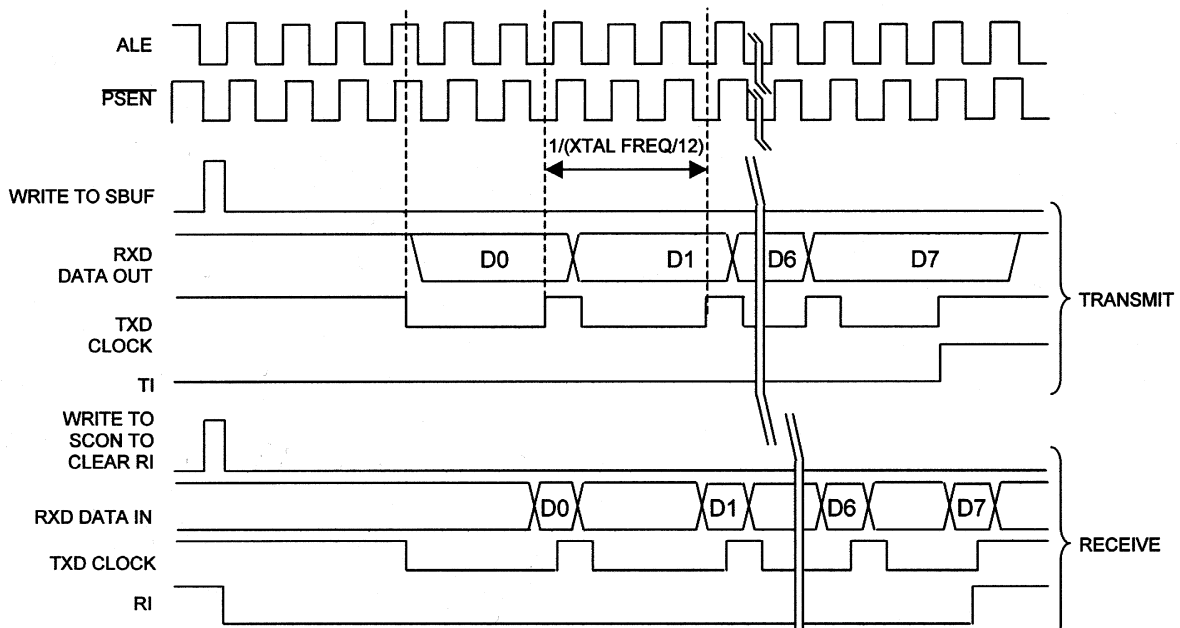

TRADITIONAL 8051 OPERATION, TXD CLOCK=XTAL/12 (SM2=0)

EXPLANATION OF AC SYMBOLS

This microcontroller uses timing parameters and symbols similar to the original 8051 family. The following list of timing symbols is provided as an aid to understanding the timing diagrams.

t	Time	P	$\overline{\text{PSEN}}$
A	Address	Q	Output data
C	Clock	R	$\overline{\text{RD}}$ signal
CE	Chip Enable	V	Valid
D	Input data	W	$\overline{\text{WR}}$ signal
H	Logic level high	X	No longer a valid logic level
L	Logic level low	Z	Tristate
I	Instruction		

POWER CYCLE TIMING CHARACTERISTICS

PARAMETER	SYMBOL	TYP	MAX	UNITS	NOTE
Crystal start-up time	t_{CSU}	1.8		ms	1
Power-on reset delay	t_{POR}		65536	t_{CLCL}	2

NOTES FOR POWER CYCLE TIMING CHARACTERISTICS

- Start-up time for crystals varies with load capacitance and manufacturer. Time shown is for an 11.0592 MHz crystal manufactured by Fox Electronics.
- Reset delay is a synchronous counter of crystal oscillations during crystal start-up. Counting begins when the level on the XTAL1 input meets the V_{IH2} criteria. At 40 MHz, this time is approximately 1.64 ms.

POWER CYCLE TIMING

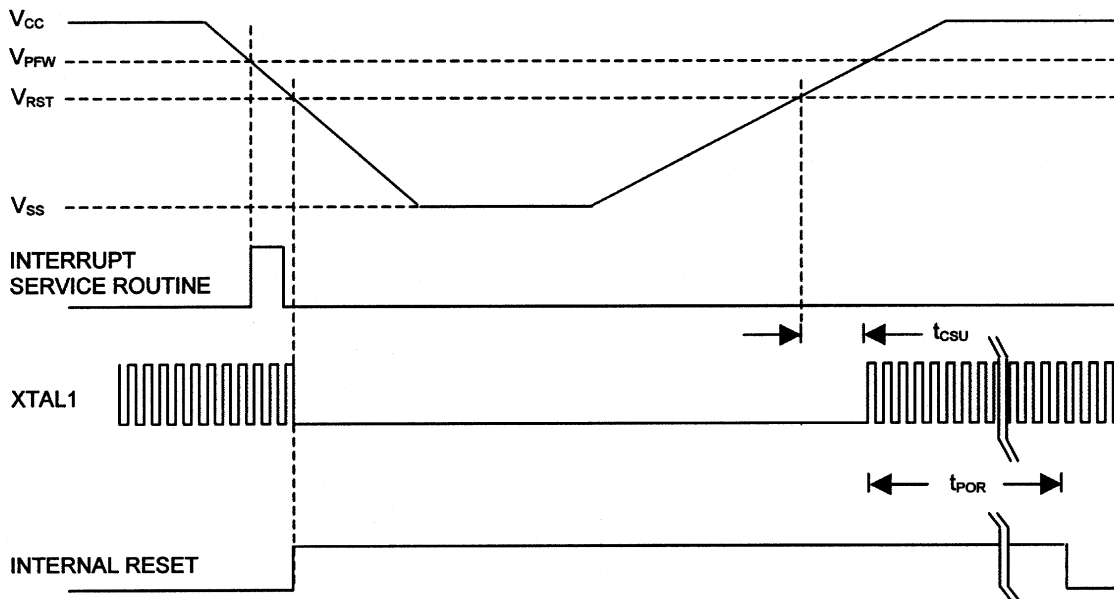

REVISION SUMMARY

1. Creation of Data Sheet 05/17/99.